

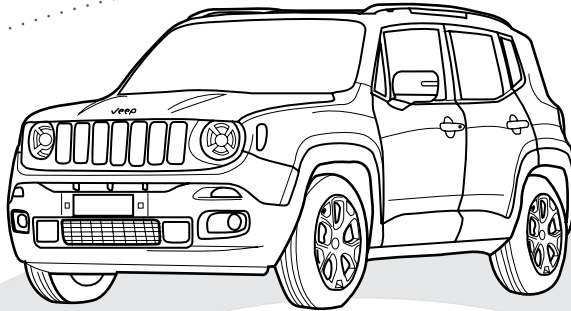

# Jeep Renegade Phase I (type BU)

10/'14 - 09/'18

PLUG-IN HYBRIDE (PHEV) ✓



# Fiat 500X (type 334)

09/'14 -

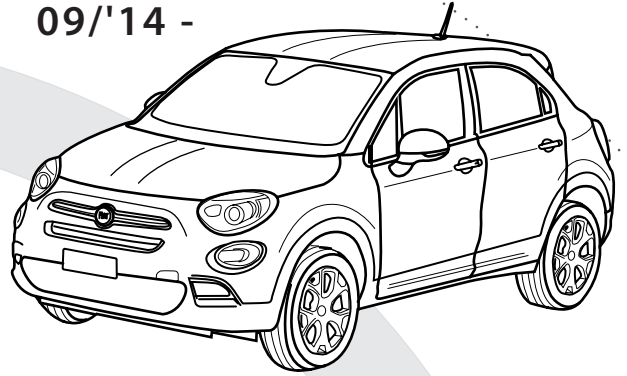

# Fiat 500X Cross + FL

09/'14 -

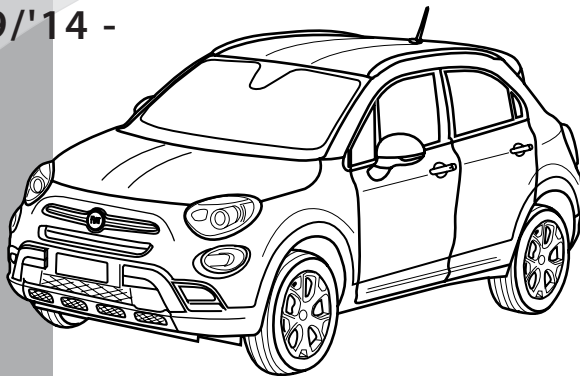

# Fiat Tipo 4D (type 356)

10/'15-

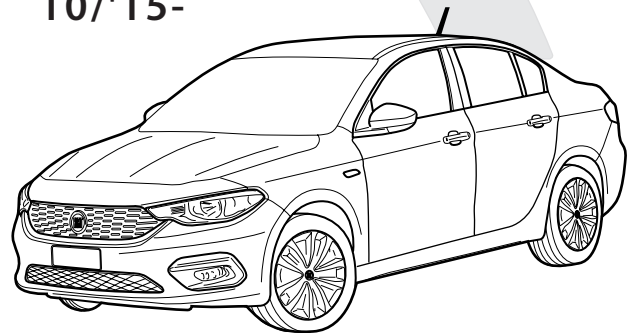

# Fiat Tipo 5D (type 357)

03/'16-

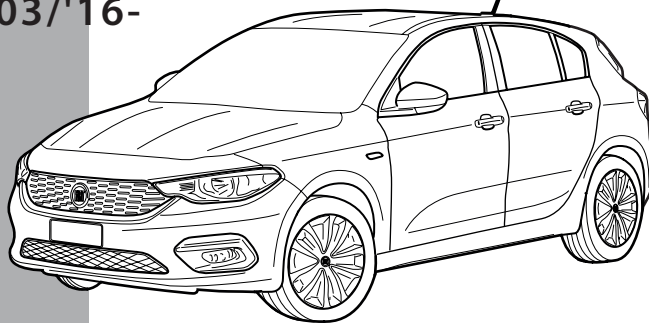

# Jeep Renegade

## Phase II (type BU)

10/'18 - PLUG-IN HYBRIDE (PHEV) ✓

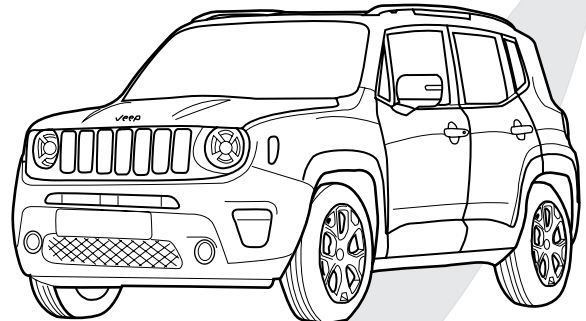

# Fiat 500X Sport +

# Fiat 500X Urban

'19 -

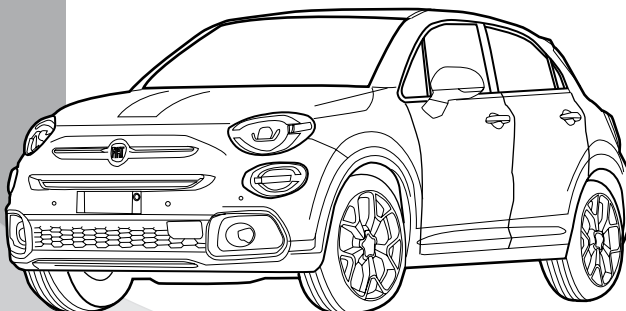

*Montage*

- Voor de montage moet de trekhaak eerst op het voertuig gepresenteerd worden.

De belasting van een aanhangwagen en van een accessoire dat op de koppelingskogel wordt voorzien, zijn anders van aard. Voor beiden kunnen verschillende limieten van toepassing zijn. Hiervoor verwijzen we naar het instructieboekje van de wagen of naar uw concessiehouder.

*Montage*

- Présenter l'attelage sous le véhicule avant d'effectuer le montage.

La charge d'une remorque ou d'un accessoire prévue sur la boule d'attelage, est de nature diverse. Pour ces deux éléments, il peut y avoir des limites d'utilisation. Nous vous recommandons de vous référer à votre livret d'instructions ou de vous renseigner chez votre concessionnaire.

*Fitting*

- Present the towbar under the car first to check if all points are right.

The load of a trailer and of an accessory fitted on the towing ball are of a different nature. Different limits may apply to both. For this matter, we refer to the instruction manual of the vehicle or we advise you to contact your concessionaire.

*Montage*

- Erst die Anhängerkupplung und das Fahrzeug kontrollieren, danach montieren.

Die Belastung eines Anhängers und eines Zubehörs, die man auf einer Kupplungskugel voraussieht, ist wesentlich anders. Für beide gilt, dass diese unterschiedlich begrenzt sein können. Deswegen möchten wir verweisen auf die Bedienungsanleitung des Fahrzeugs oder auf Ihren Vertragshändler.

*Montaje*

- Presentar el enganche debajo del vehículo antes de realizar el montaje.

La carga de un remolque y un accesorio montado en una bola de remolque son de una naturaleza diferente. Se pueden aplicar diferentes límites a ambos. Para este asunto, nos referimos al manual de instrucciones del vehículo o le recomendamos que contacte a su distribuidor.

*Montering*

- Præsenter trækstangen under bilen først for at kontrollere, om alle punkter er rigtige.

Belastningen af en trailer og af tilbehør tilkoblet anhængertrækket er forskellige. Der kan være forskellige begrænsninger på begge. I disse tilfælde henviser vi til bilens manual, eller anbefaler dig at kontakte bilforhandleren

*Montaggio*

- In primo luogo, presentare la struttura sotto l'automobile per verificare che tutti i punti di attacco coincidano.

La massa rimorchiabile del veicolo potrebbe essere diversa dal valore riportato sul documento del gancio di traino. Per questo motivo, vi invitiamo a consultare sempre la carta di circolazione del veicolo (Pos. O.1) o a rivolgervi alla vostro concessionario di fiducia

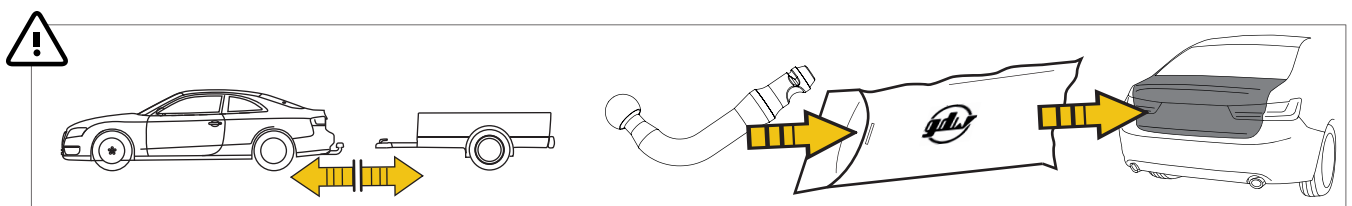
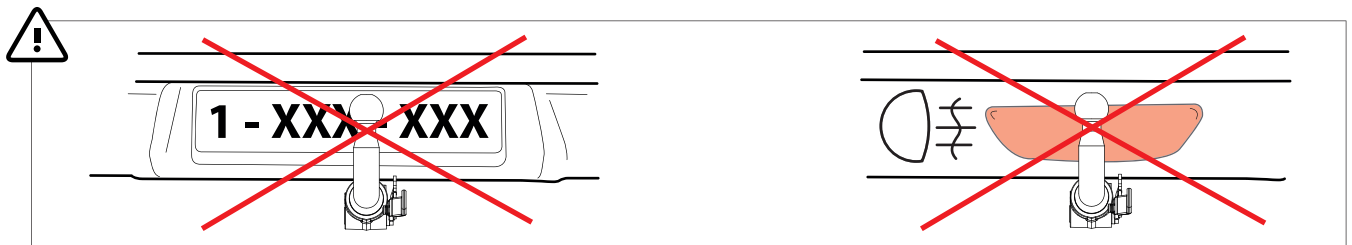
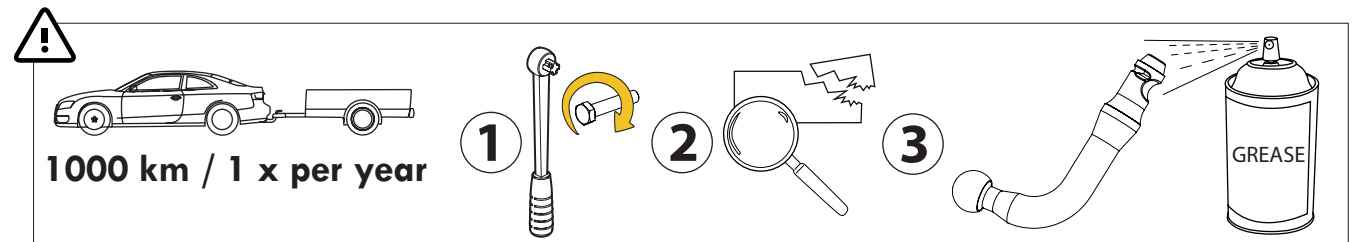
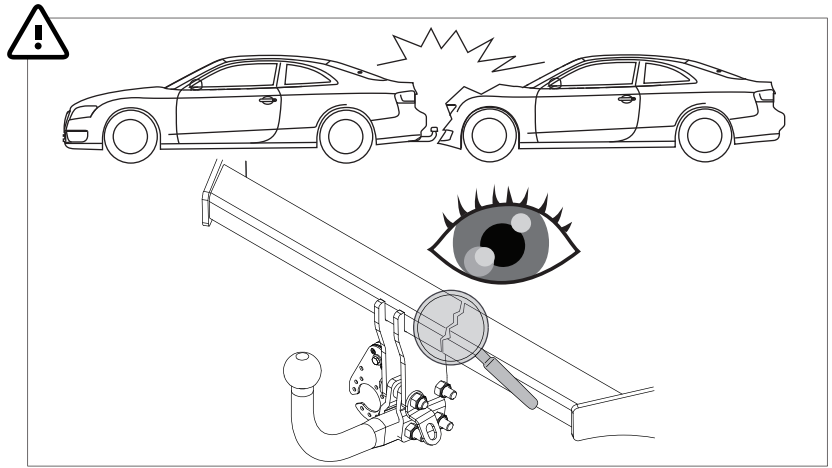
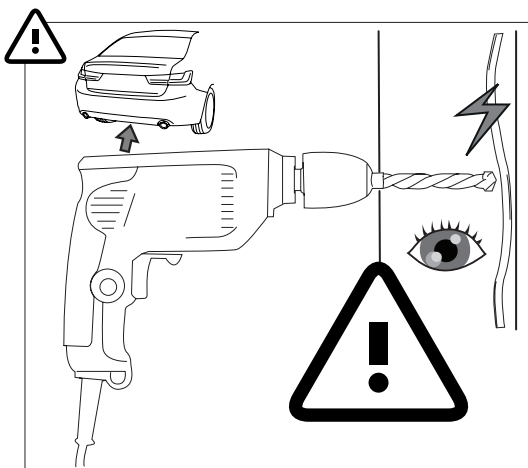
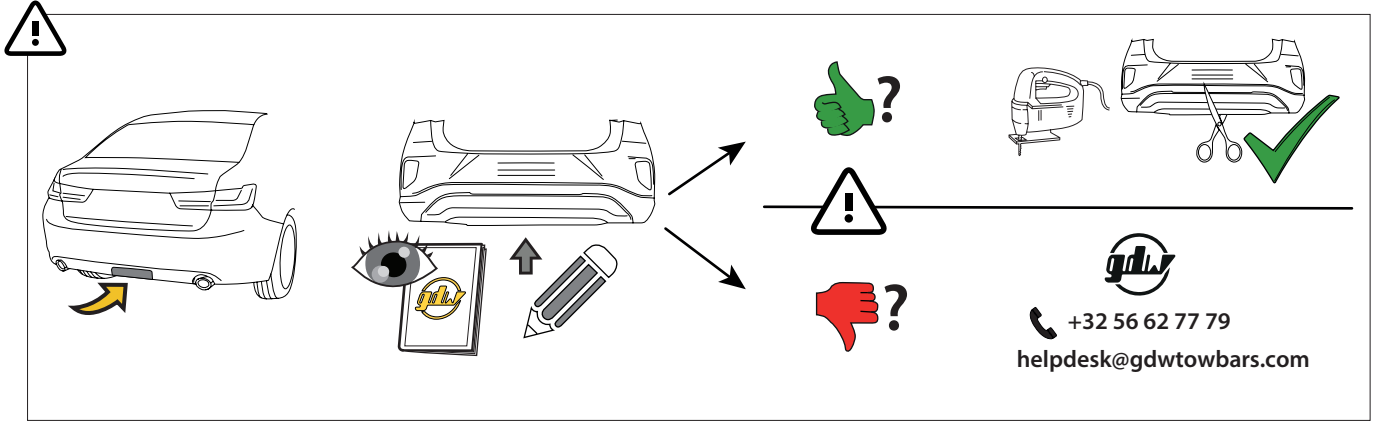
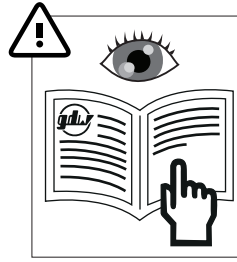
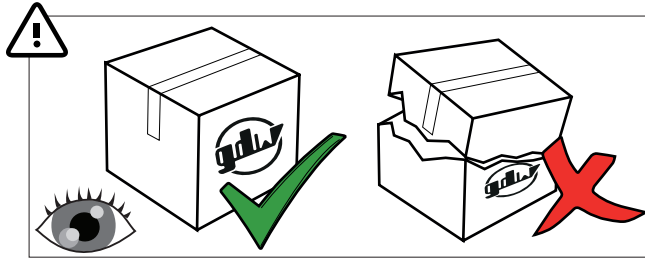



MADE BY  **D 9,95** **F** **E6**

BELGIUM **S 100** **55R-011618**

REF N° **2486** **SERIAL N° XXXX**







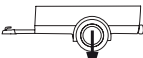

**DESCRIPTION**  
 Jeep Renegade Phase I / Fiat 500X /  
 Fiat 500X-Cross + FL / Fiat Tipo 4D / Fiat Tipo 5D /  
 Jeep Renegade Phase II / Fiat 500X Sport / Fiat 500X Urban







 



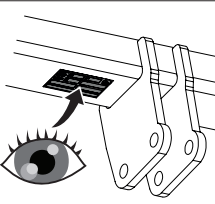
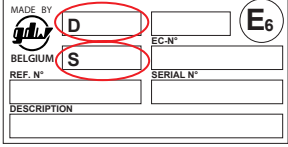

**D =**  $\frac{\text{max kg (car)} \times \text{max kg (trailer)}}{\text{max kg (car)} + \text{max kg (trailer)}} \times 0.00981 \leq 9,95 \text{ kN}$

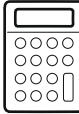
**S =**   $\leq 100 \text{ kg}$    $\leq 1800 \text{ kg}$

See the Certificate Of Conformity (COC) of your vehicle or contact your dealer to verify the max. trailer weight of your car!



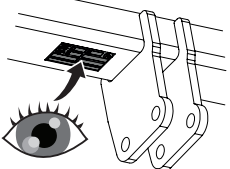
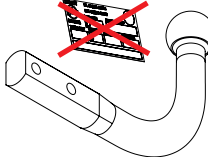
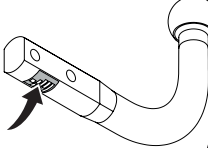



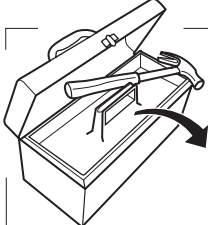
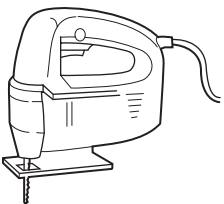







      **D-VALUE** **S-LOAD**  

   **A50-X?**  **F?**  

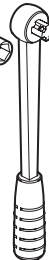

**19** **22** **13** **7** **TX30** **PH2** **PZ2**

**JEEP RENEGADE ONLY**   **Ø6**



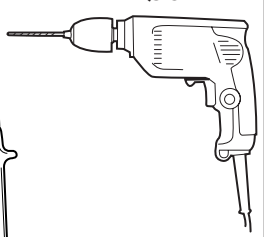

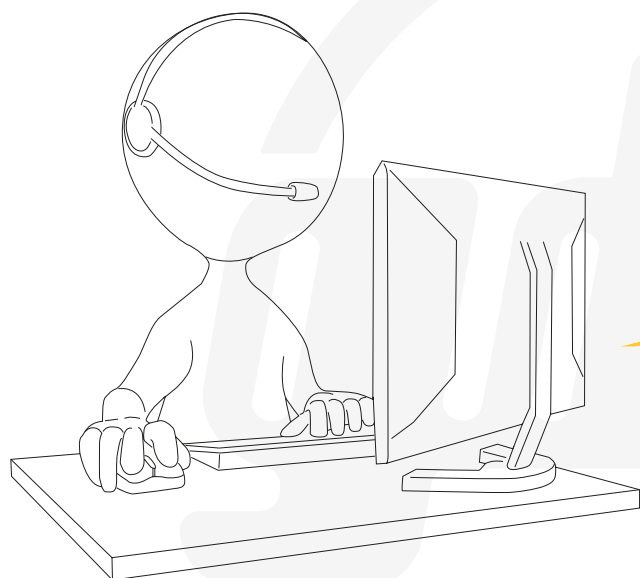



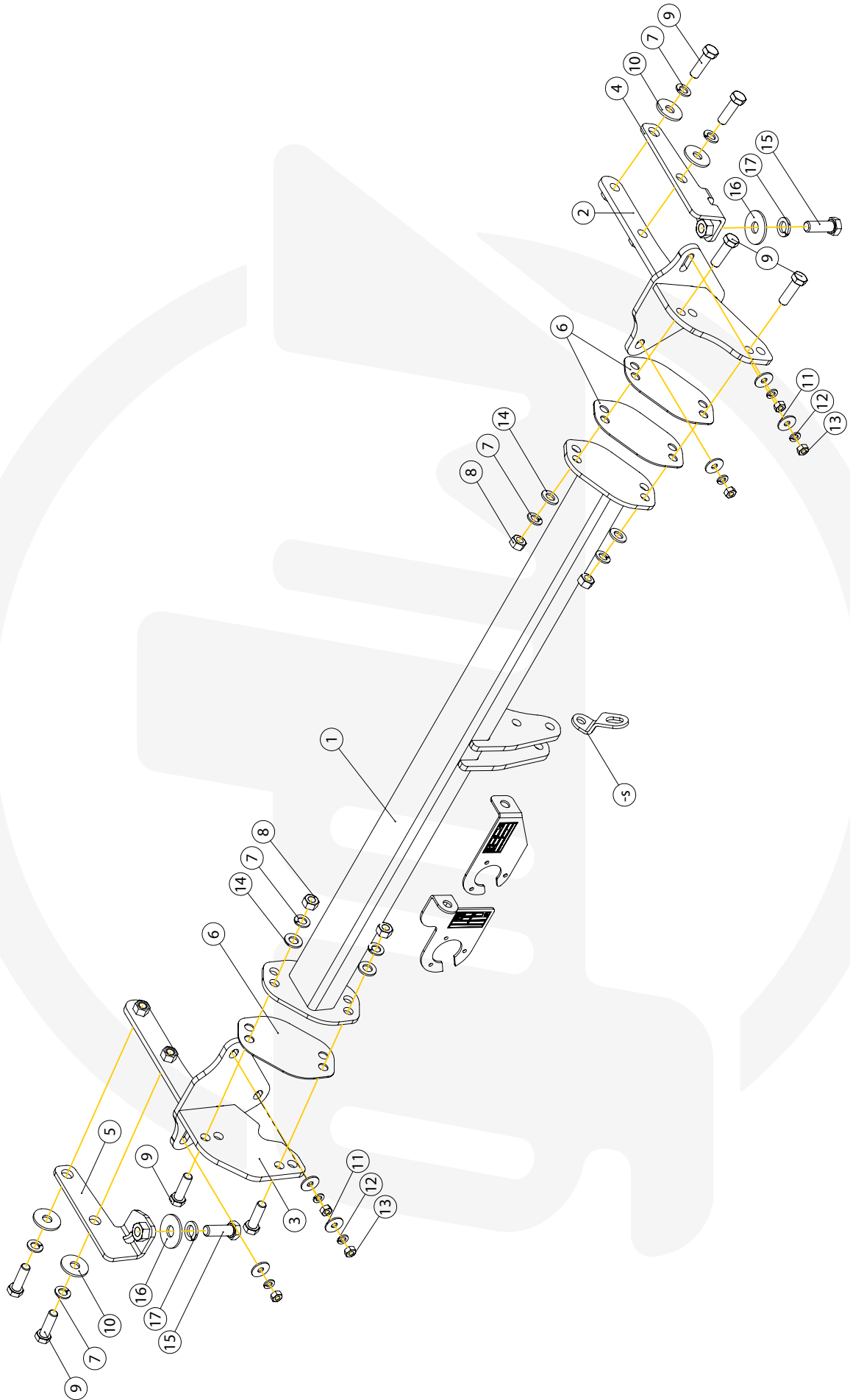

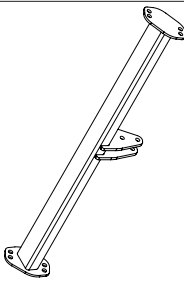
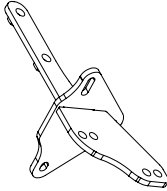
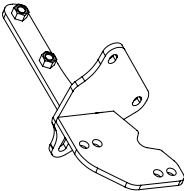
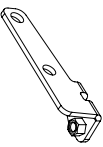
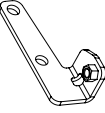



**helpdesk@gdwtowbars.com**  
**+32 56 62 77 79**

Monday	08:00 - 12:00	12:30 - 16:30
Tuesday	08:00 - 12:00	12:30 - 16:30
Wednesday	08:00 - 12:00	12:30 - 16:30
Thursday	08:00 - 12:00	12:30 - 16:30
Friday	08:00 - 12:00	12:30 - 15:30











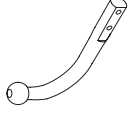

1		X1	GDW REF. 2486
2		X1	GDW REF. 2
3		X1	GDW REF. 3
4		X1	GDW REF. 4
5		X1	GDW REF. 5
6		X3	GDW REF. 6
7		X8	DIN128A-M12
8		X4	DIN934-M12
9		X8	DIN933-M12X40
10		X4	DIN9021-M12-ELVZ
11		X6	DIN9021-M8-ELVZ
12		X6	DIN128A-M8

13		X6	DIN934-M8
14		X4	DIN125-A12-140HV-ELVZ
15		X2	DIN933-M14X40
16		X2	DIN9021-M14-ELVZ
17		X2	DIN128A-M14

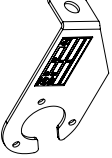
/		X7	DIN7337 Ø4,8X16
JEEP RENEGADE			

Geleverd met - Livré avec - Delivered with Geliefert mit - Elementos adjuntos - Leverages med - Forniti insieme		
	X1	944-H019
	X1	GDW REF. 900.025
	X1	GDW REF. 900.026
	X2	GDW REF. 900.011 Ø 21.3 X 11.7
	X1	GDW REF. 900.053
	X4	DIN931-M12 X 70
	X4	DIN985-M12
	X1	GDW REF. P07
JEEP RENEGADE		
	X1	GDW REF.P04
FIAT 500X / 500X-CROSS / TIPO 4D / TIPO 5D		



# Jeep Renegade Phase I

10/'14 - 09/'18

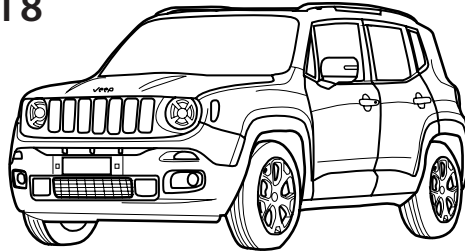

1	—	9
23	—	30
32	—	34
41	—	44

# Jeep Renegade Phase II

10/'18 -

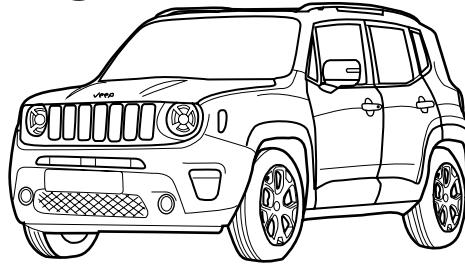

# Fiat 500X

'15 -

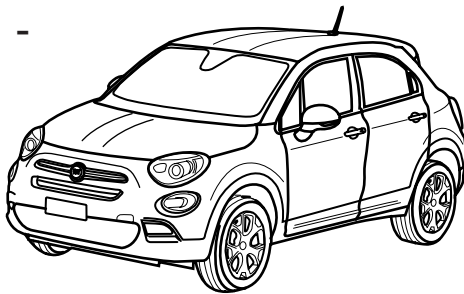

10	—	14
23	—	30
35		
41	—	42
45	—	46

# Fiat 500X-cross

'15 - '18

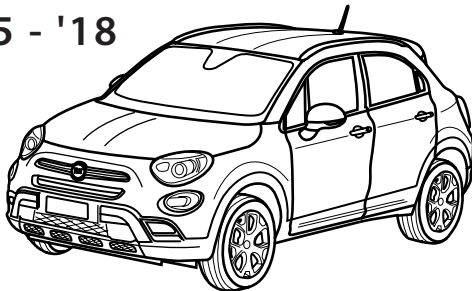

10	—	14
23	—	30
36		
41	—	42
45	—	46

# Fiat Tipo 4D

'16 -

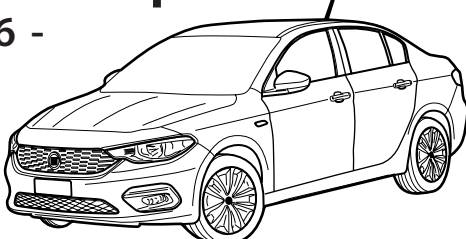

15	—	16
19	—	30
37		
41	—	42
45	—	46



# Fiat Tipo 5D

'16 -

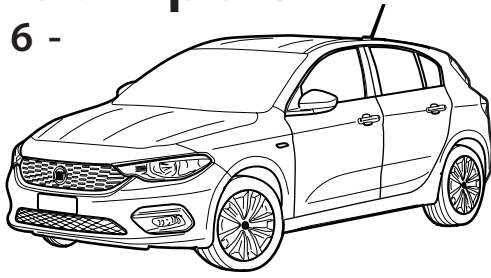

➔	17	—	30
	38		
	41	—	42
	45	—	46

# Fiat 500X Cross Facelift

'19 -

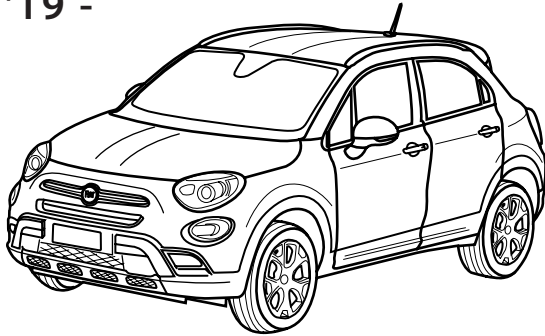

➔	10	—	14
	23	—	29
	31		
	36		
	41	—	42
	45	—	46

# Fiat 500X Urban

'19 -

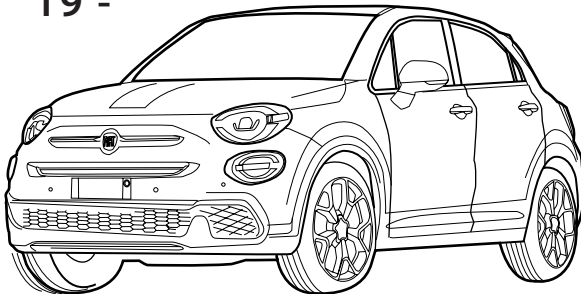

➔	10	—	14
	23	—	29
	31		
	39		
	41	—	42
	45	—	46

# Fiat 500X Sport

'19 -

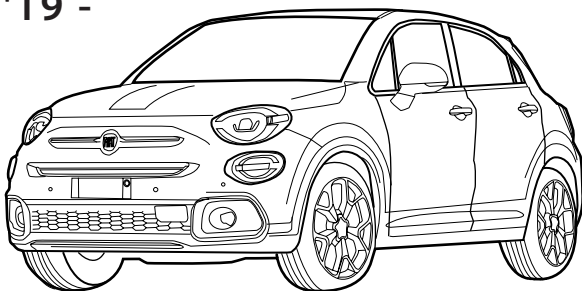

➔	10	—	14
	23	—	30
	40		
	41	—	42
	45	—	46

1

JEEP RENEGADE

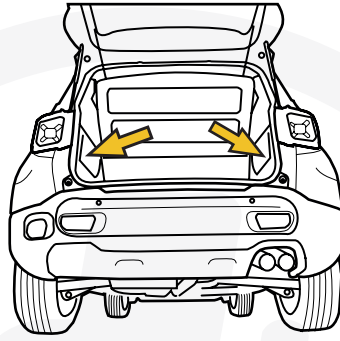

1

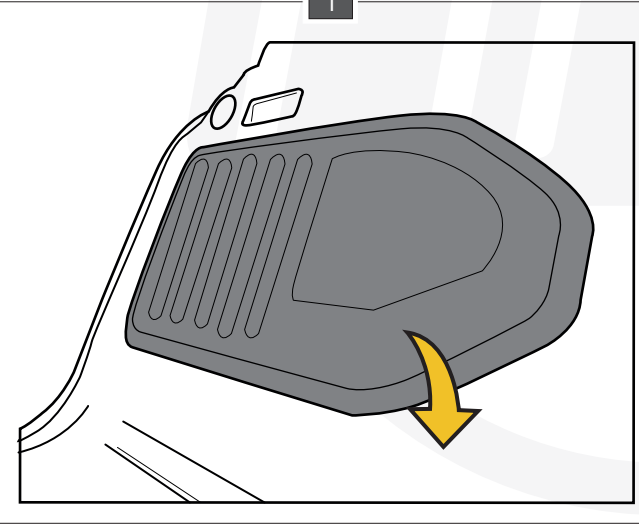

2

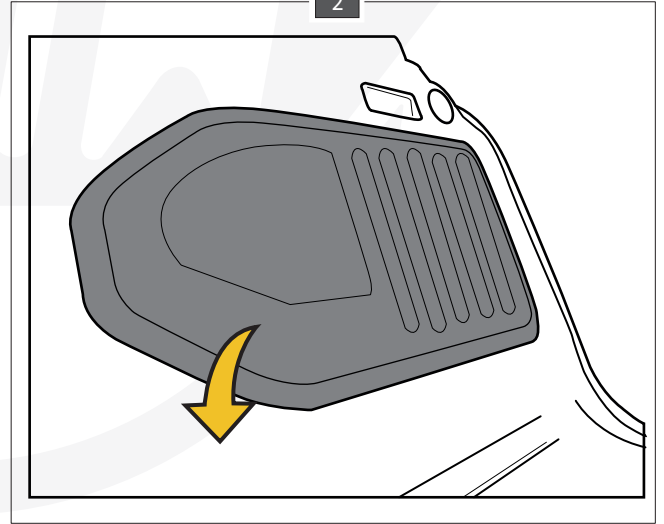

2

JEEP RENEGADE

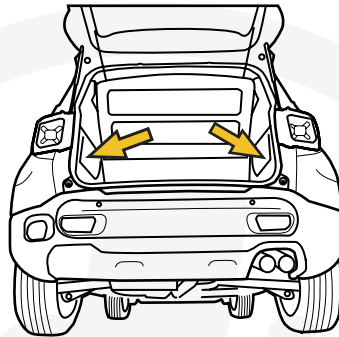

1

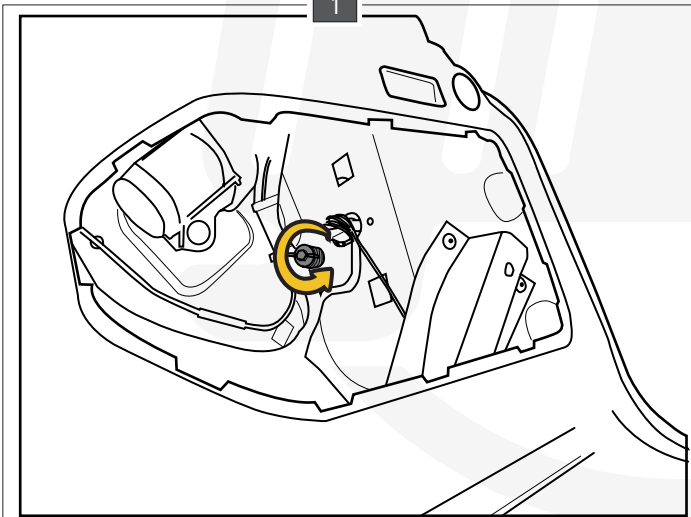

2

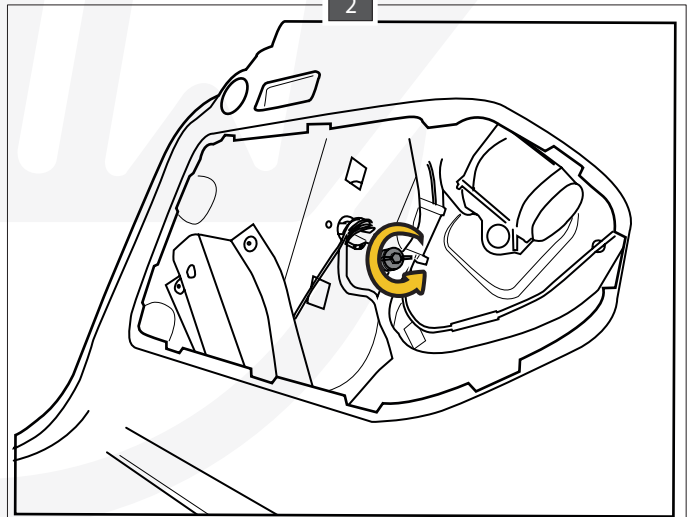

3 JEEP RENEGADE

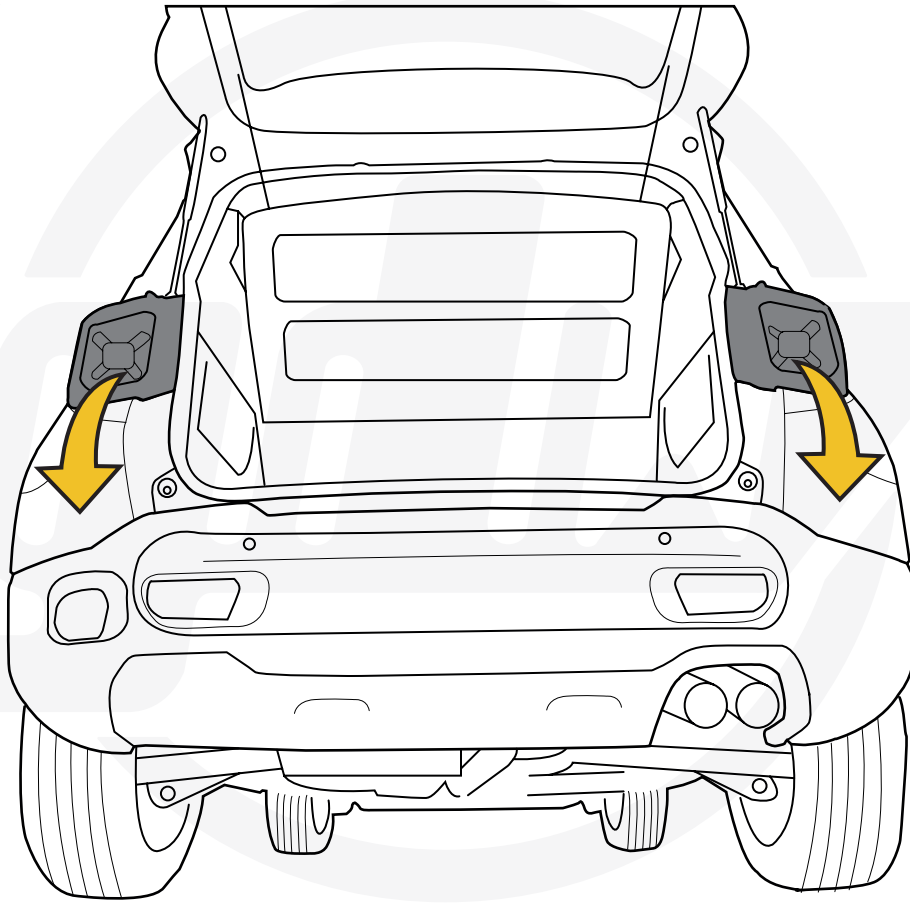

4 JEEP RENEGADE

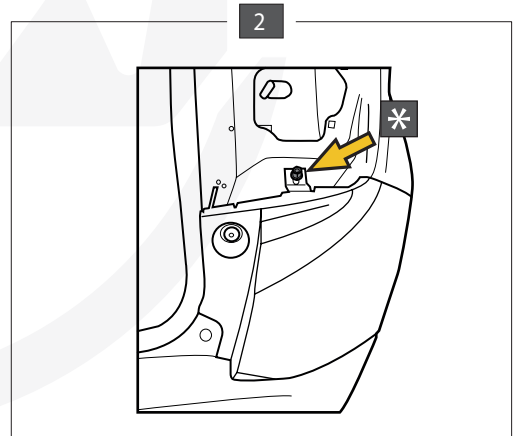
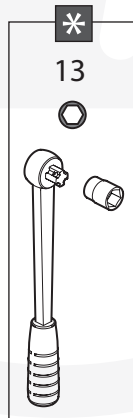
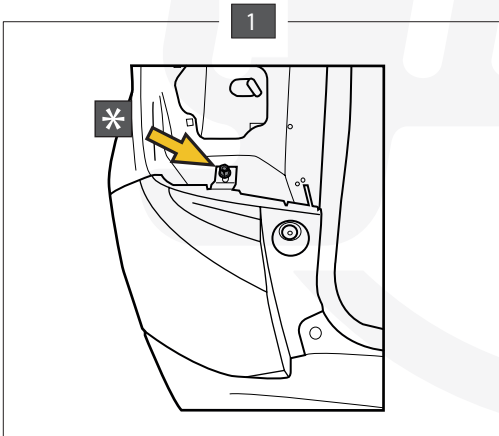
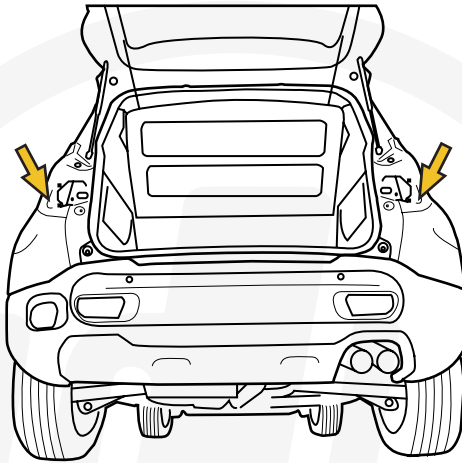

5 JEEP RENEGADE

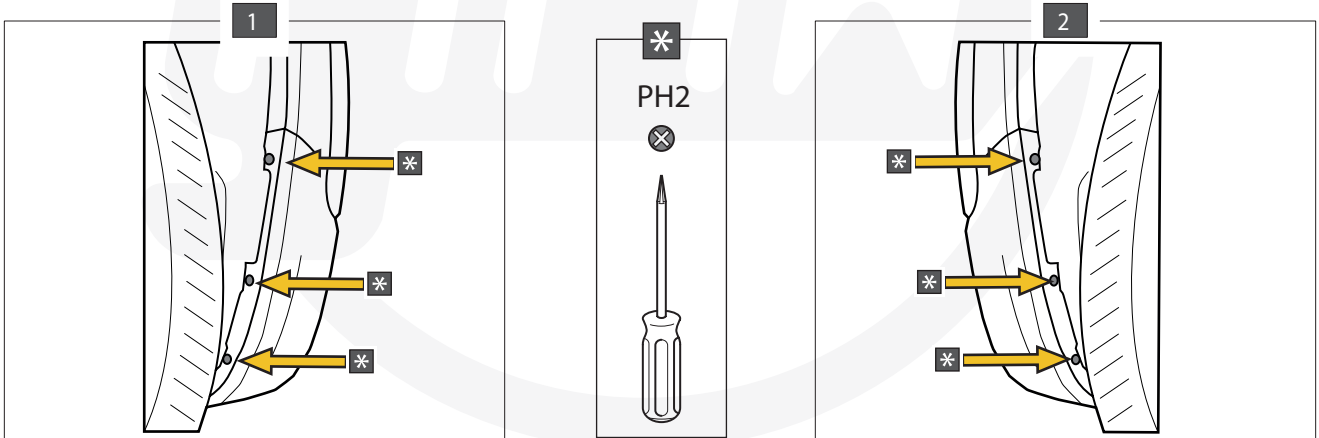
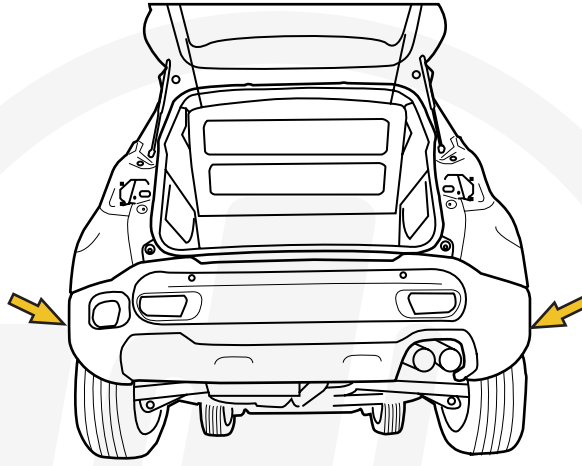

6 JEEP RENEGADE

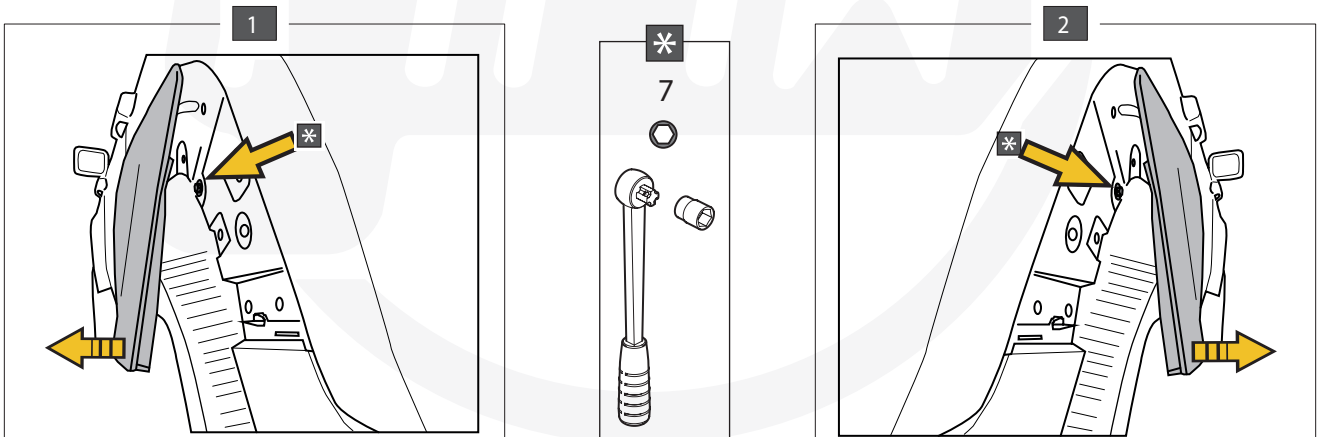
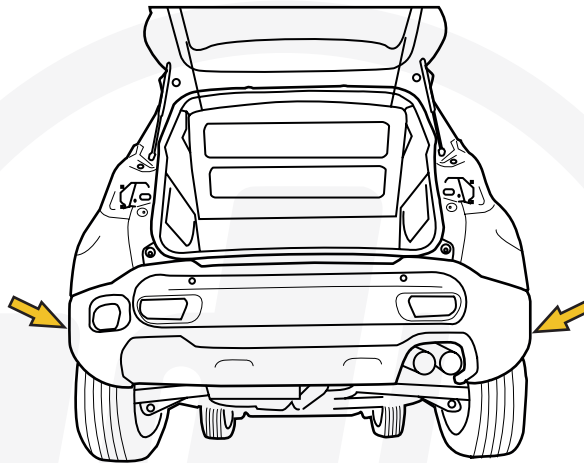

7 JEEP RENEGADE

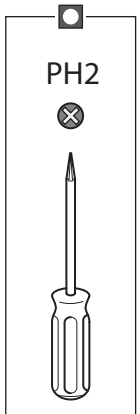
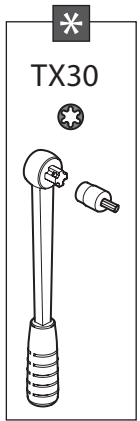
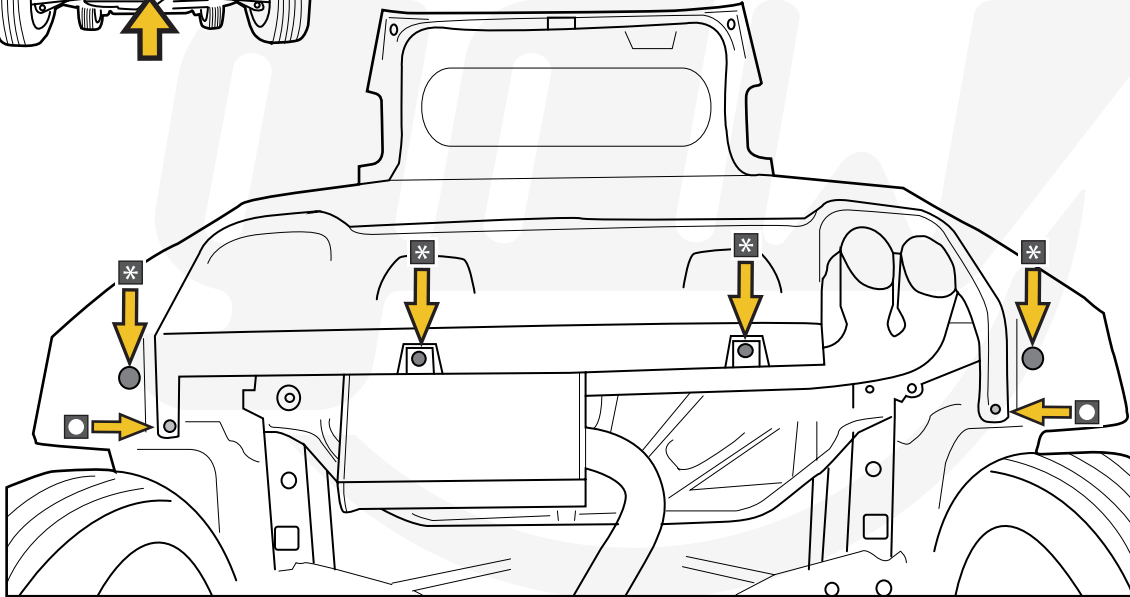
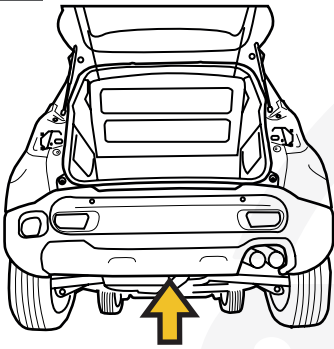

8 JEEP RENEGADE

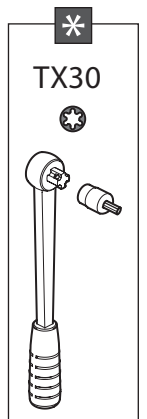
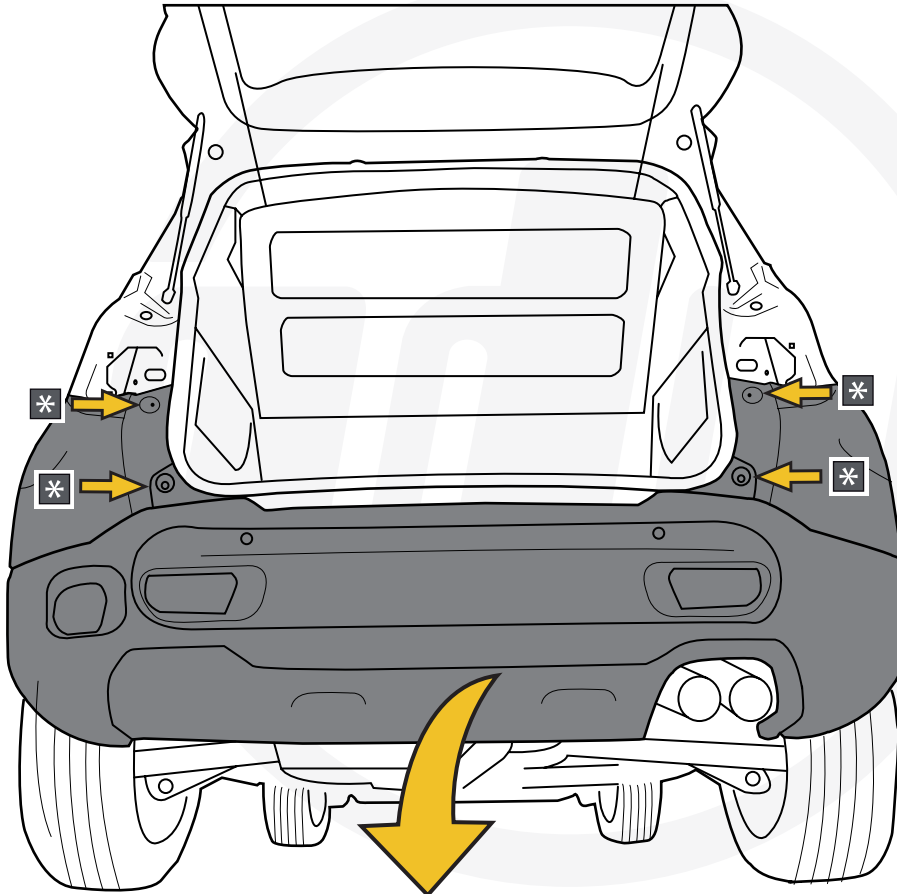

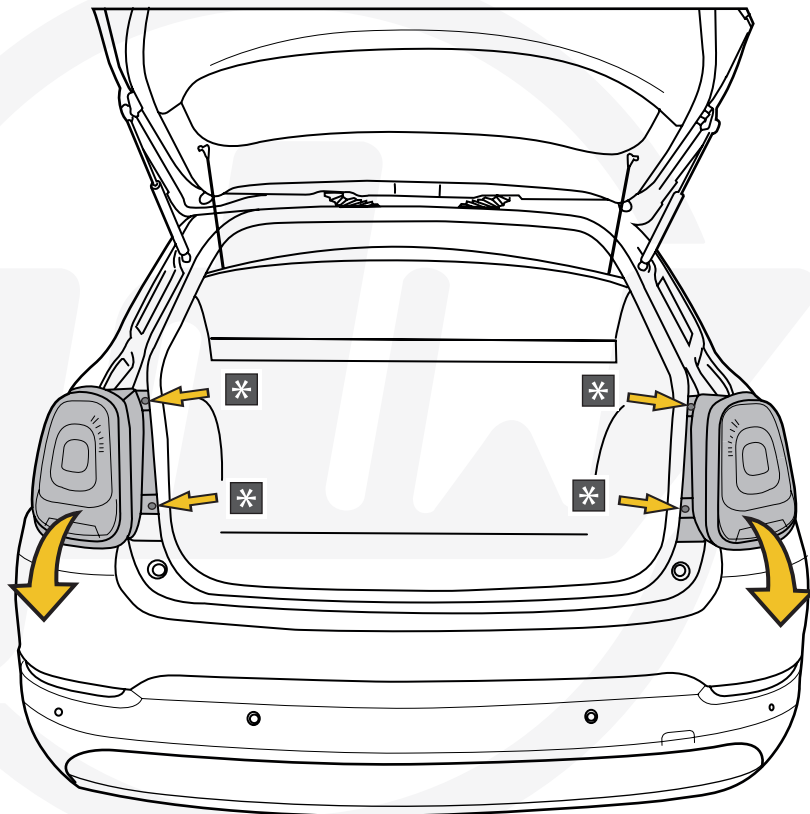
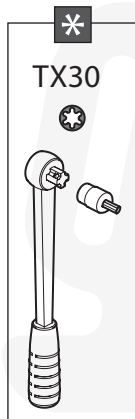
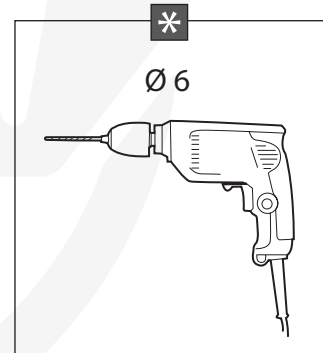
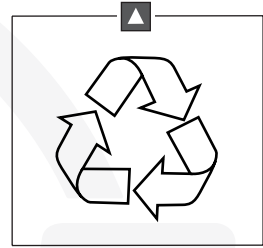
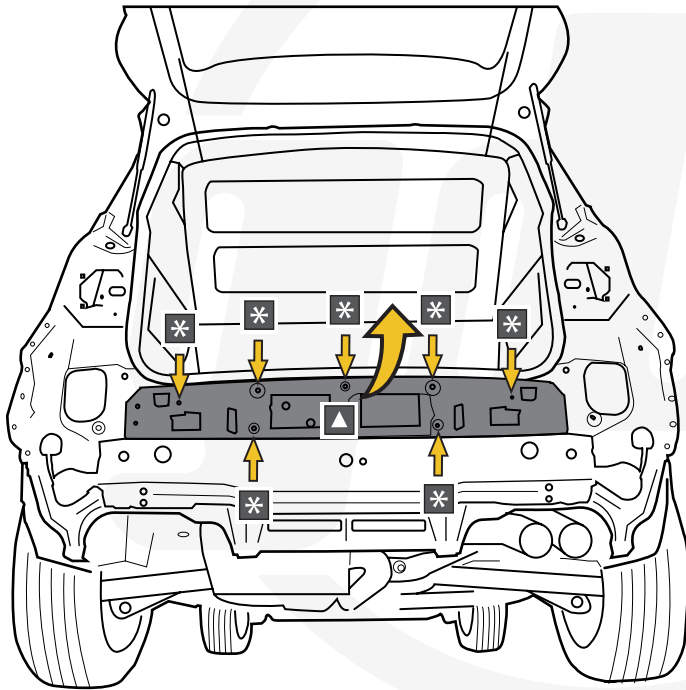

11 FIAT 500X / 500X-CROSS + FACELIFT + 500X URBAN + 500X SPORT

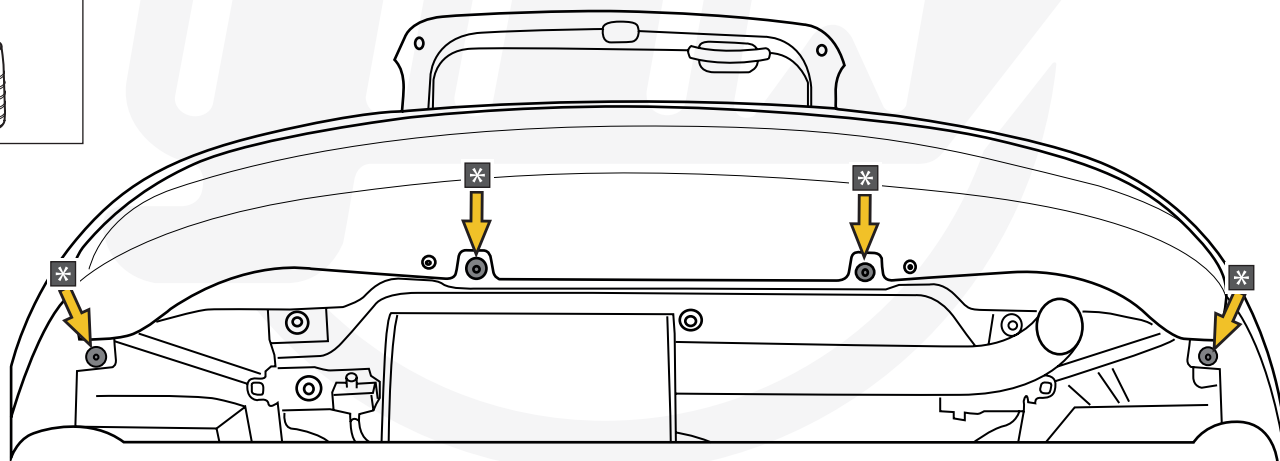
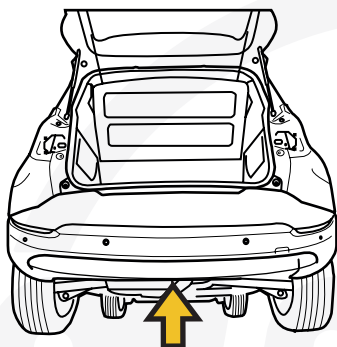
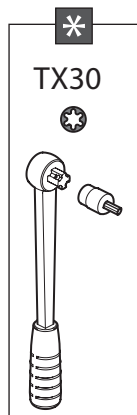

12 FIAT 500X / 500X-CROSS + FACELIFT + 500X URBAN + 500X SPORT

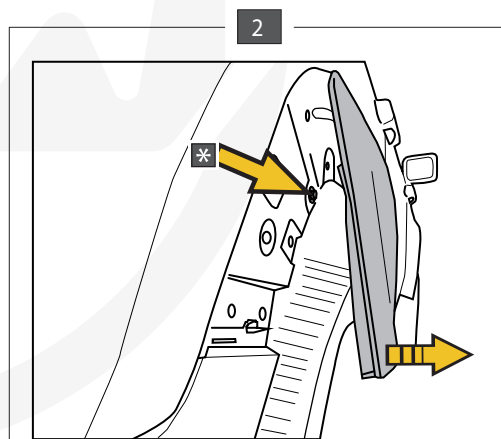
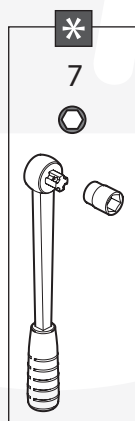
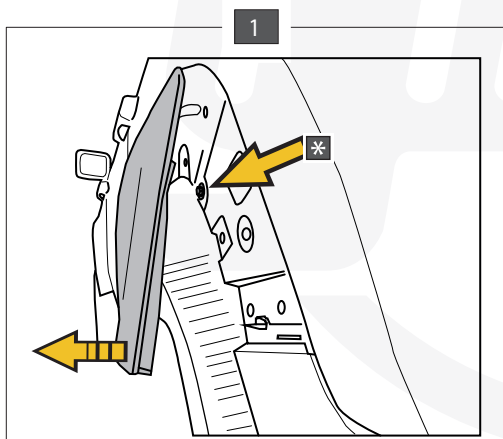
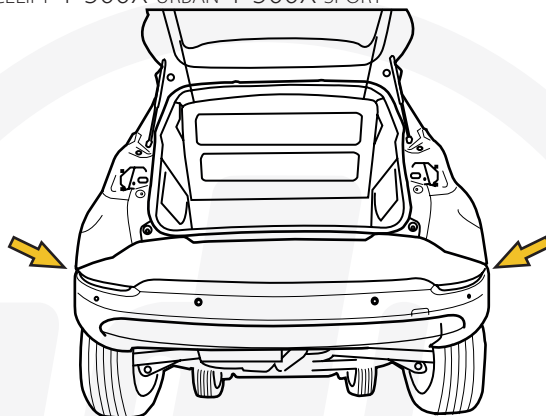



13 FIAT 500X / 500X-CROSS + FACELIFT +  
500X URBAN + 500X SPORT

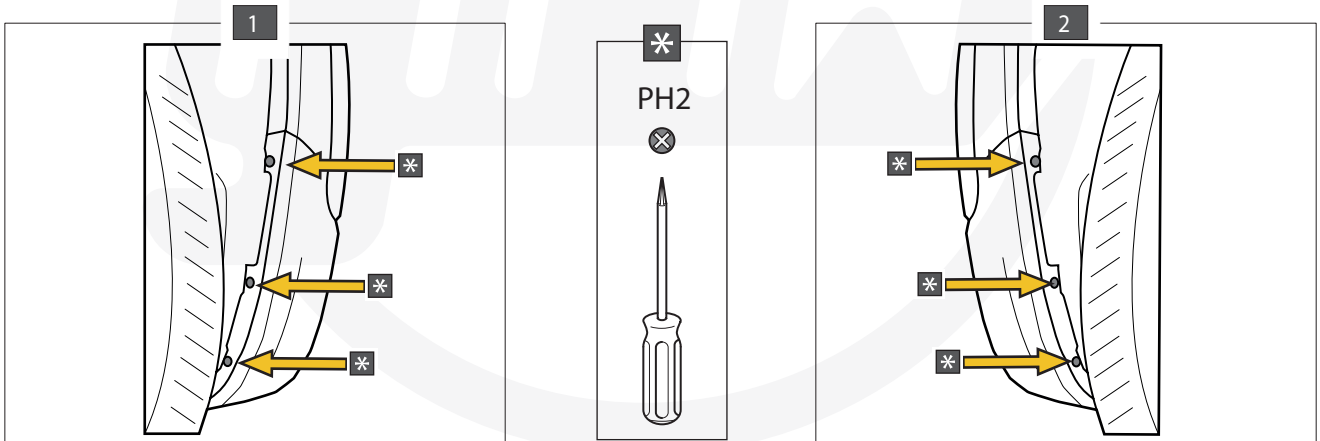
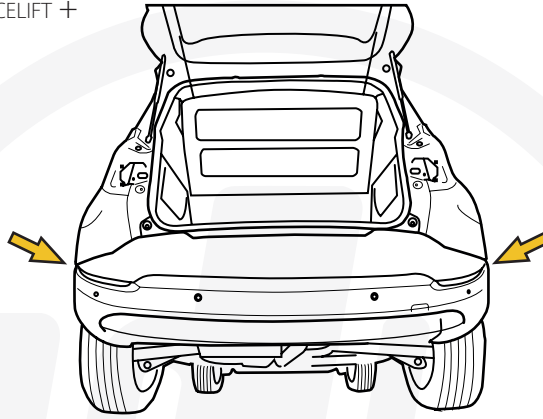

14 FIAT 500X / 500X-CROSS + FACELIFT + 500X URBAN + 500X SPORT

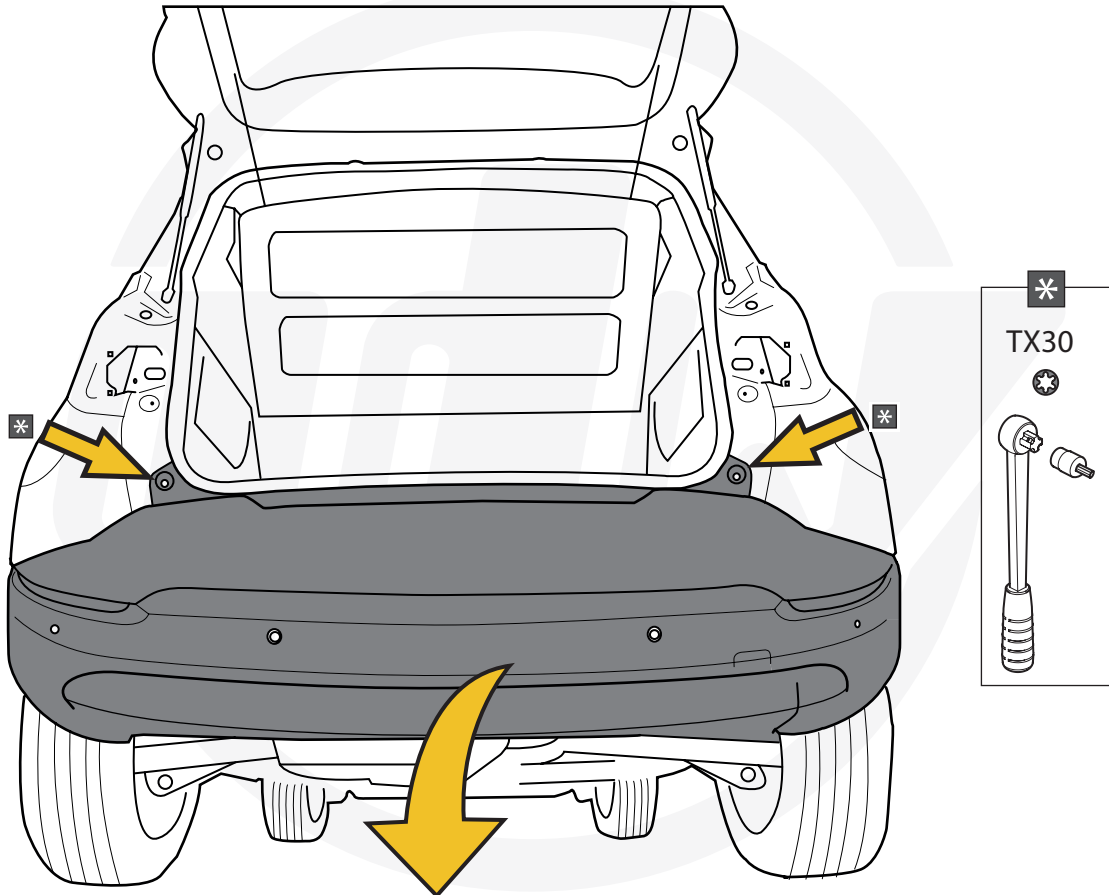

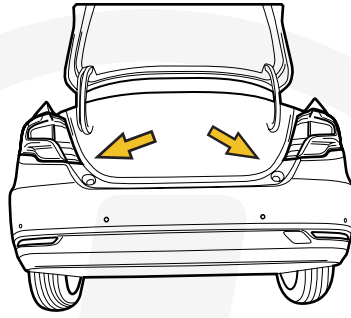

1

2

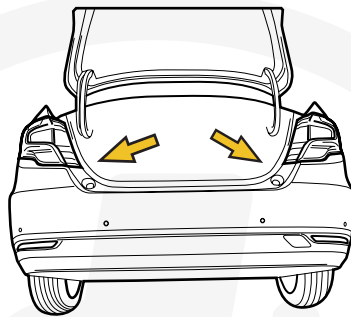
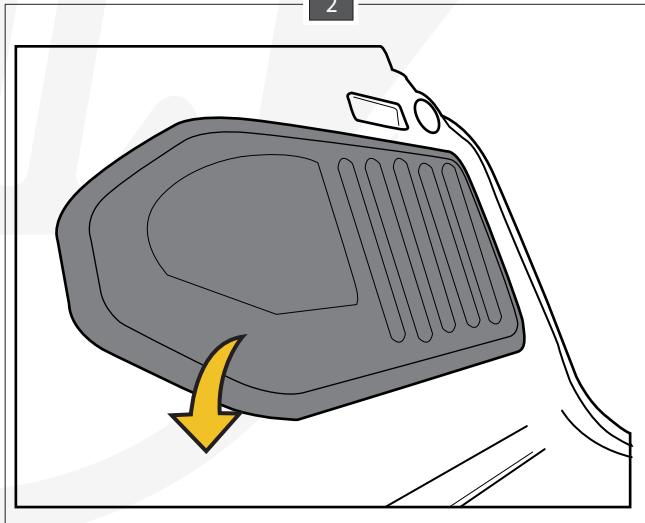
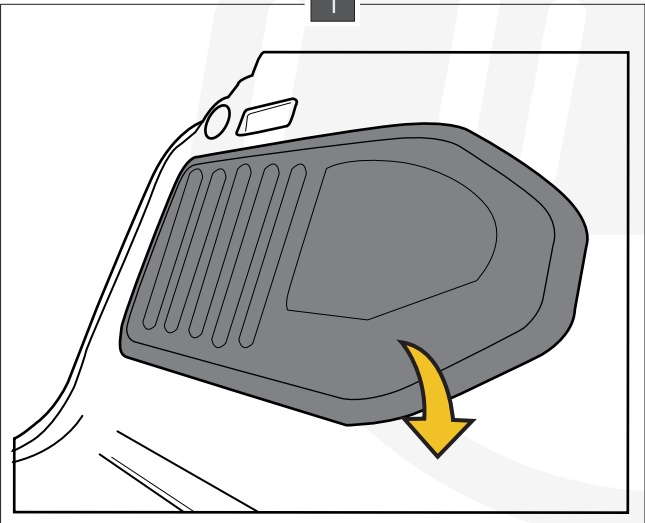

1

2

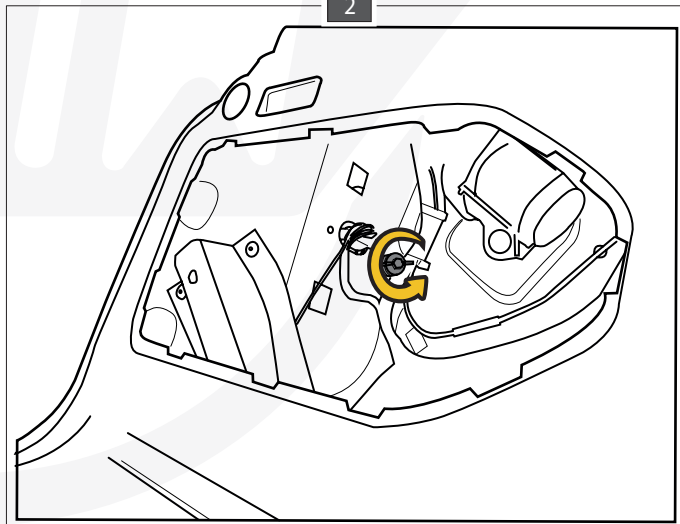
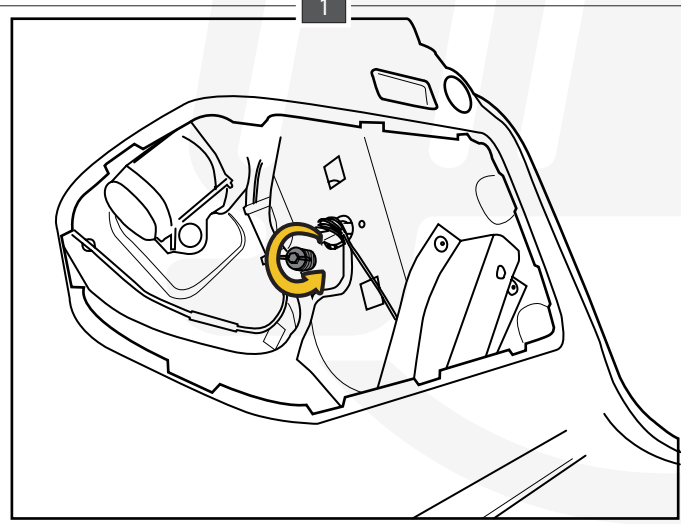

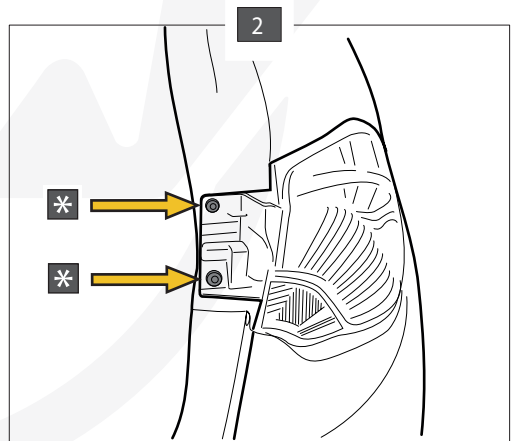
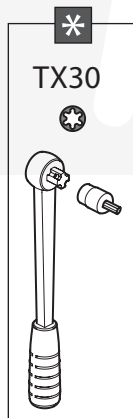
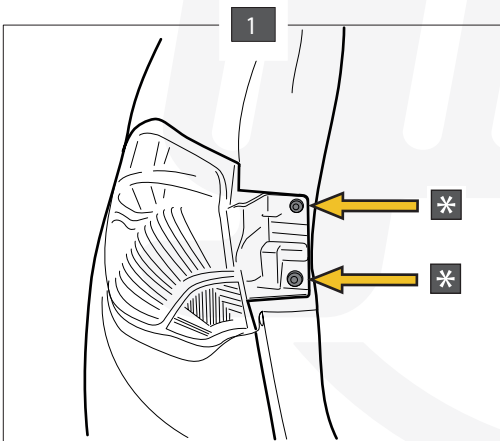
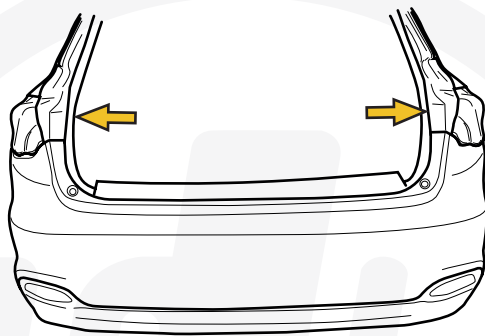
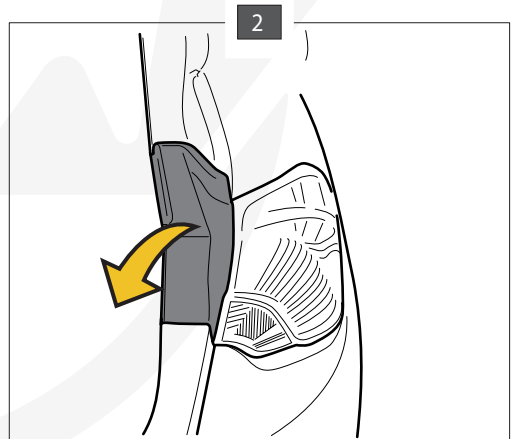
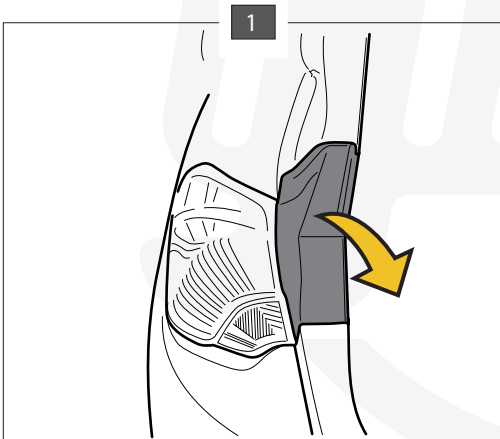
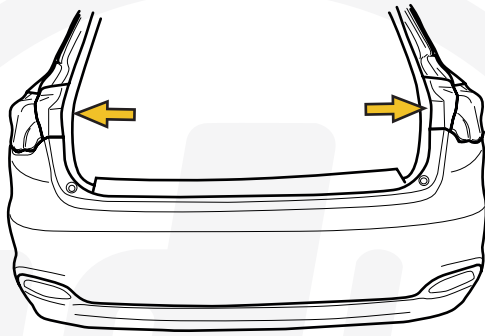

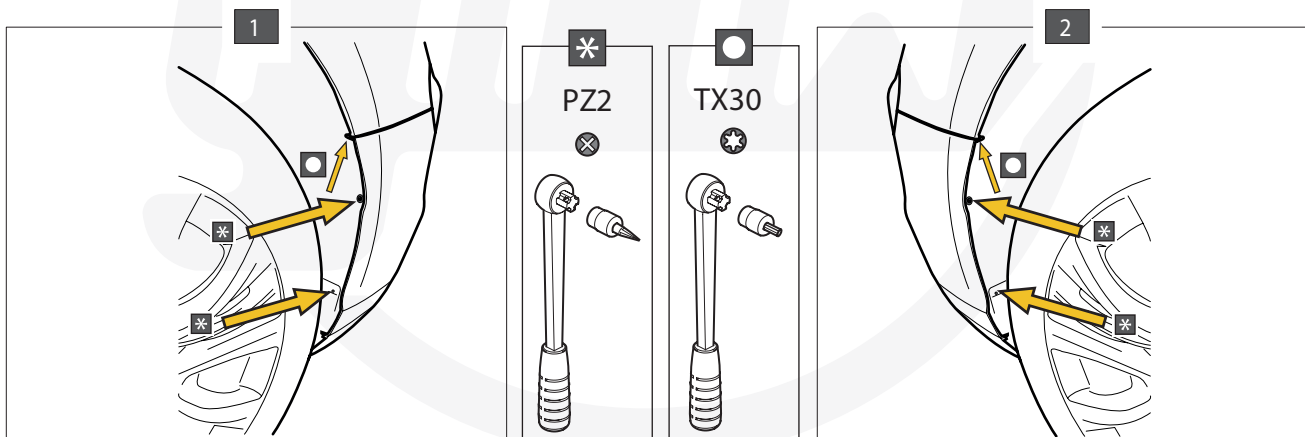
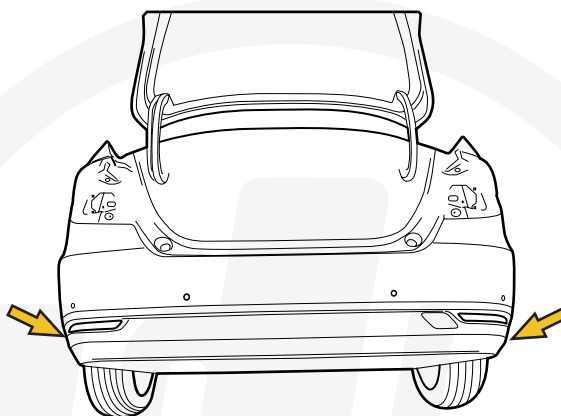
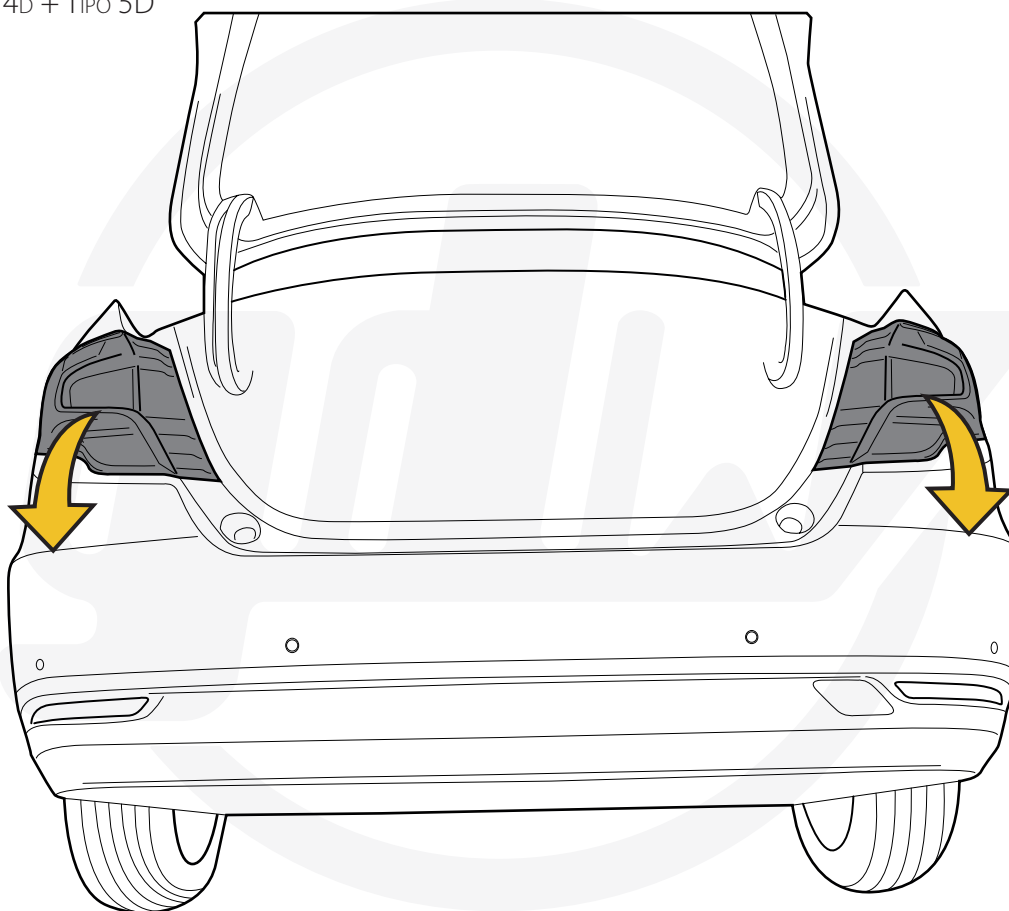

21 FIAT TIPO 4D + TIPO 5D

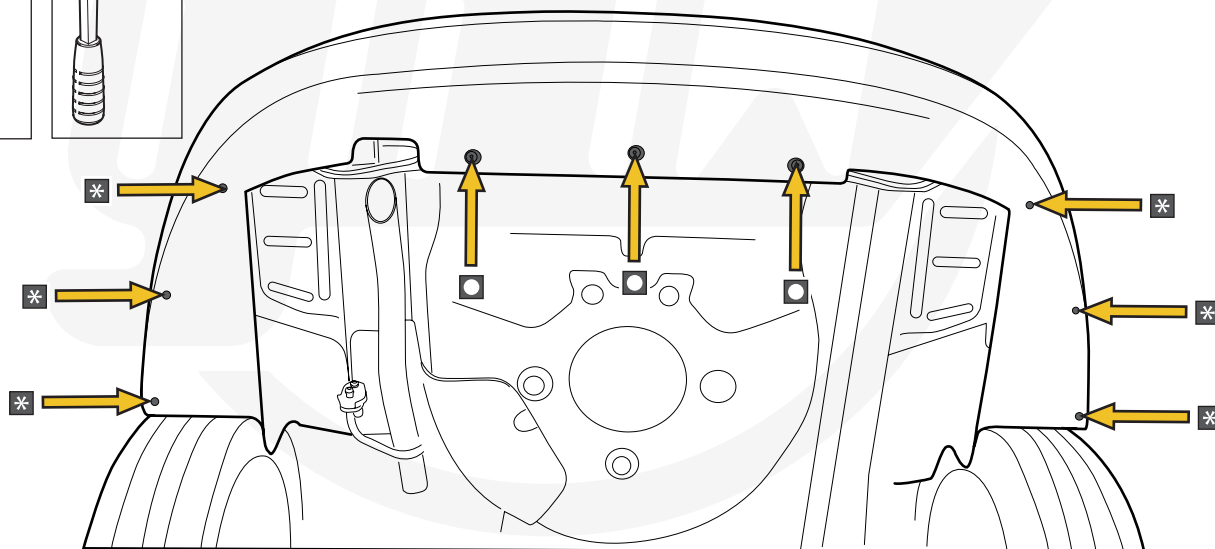
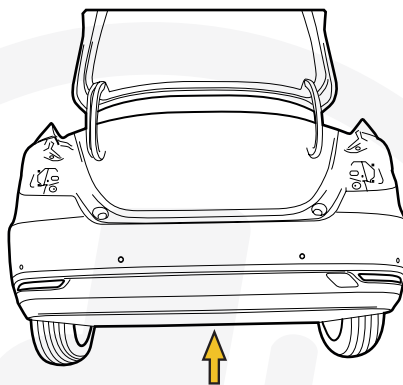
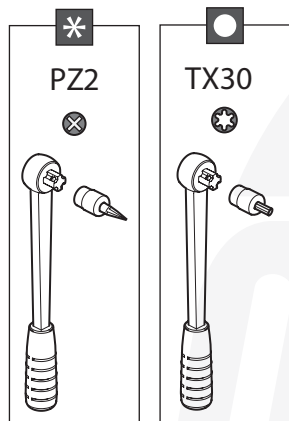

22 FIAT TIPO 4D + TIPO 5D

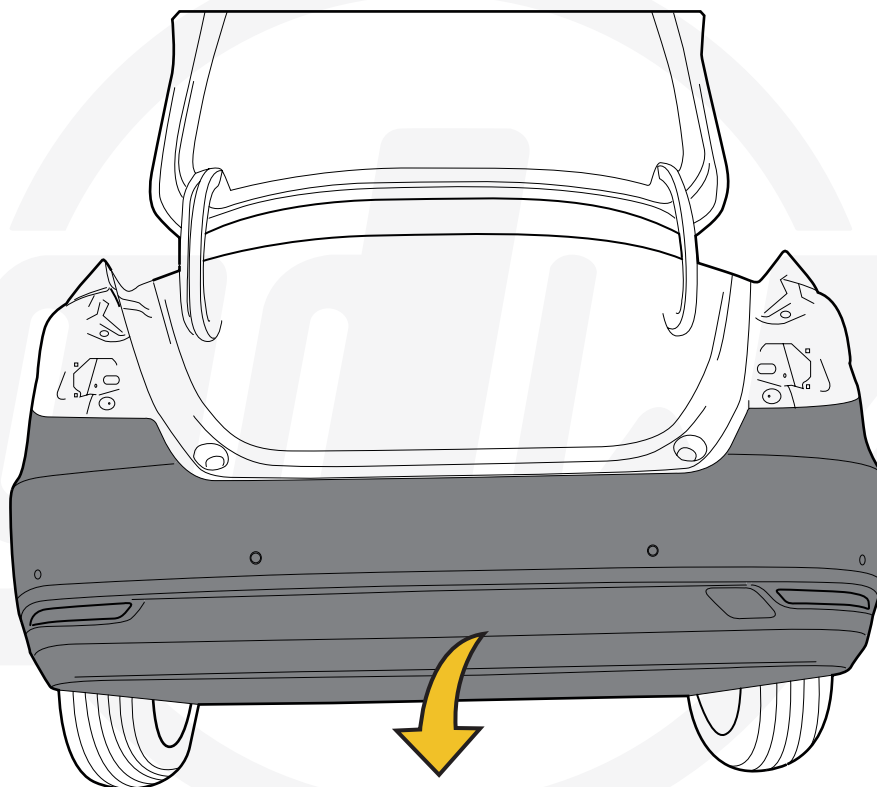

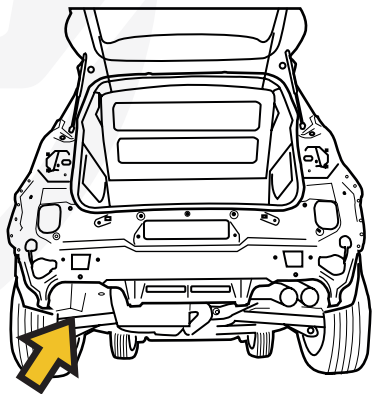
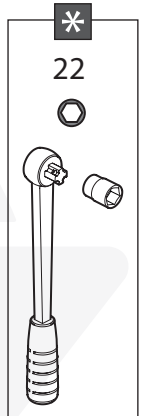
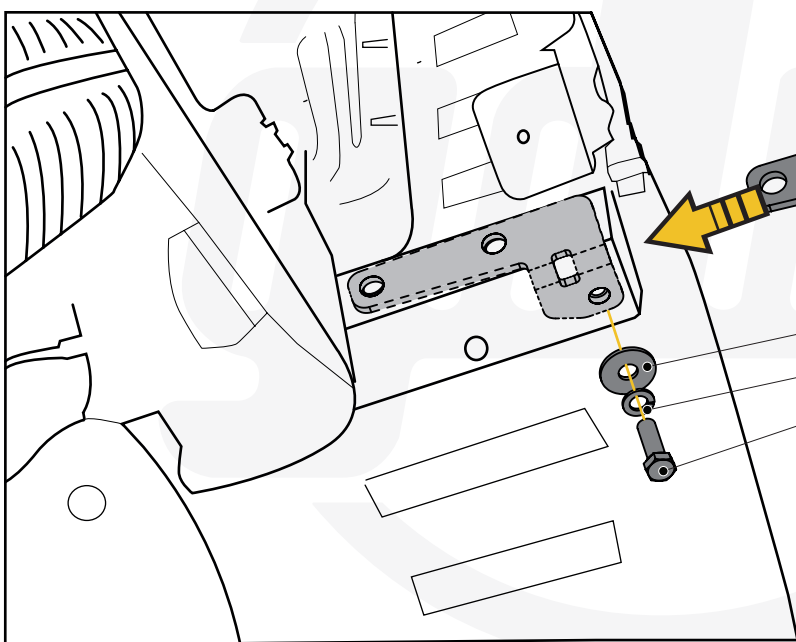
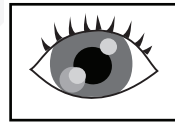
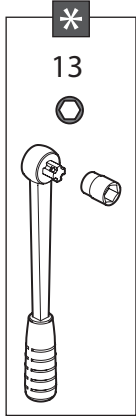
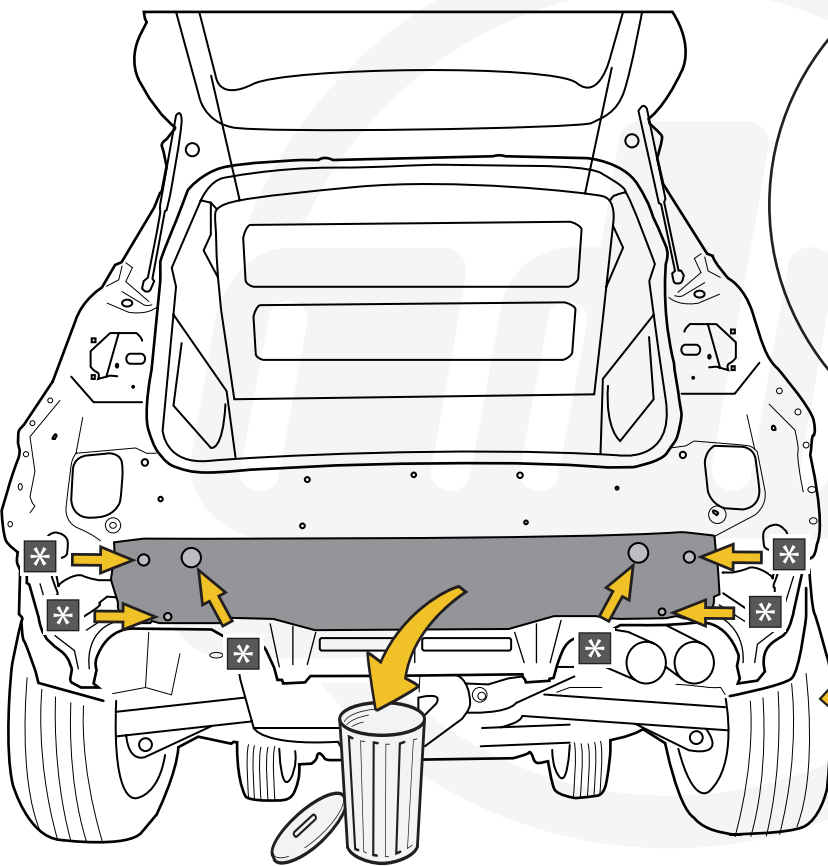

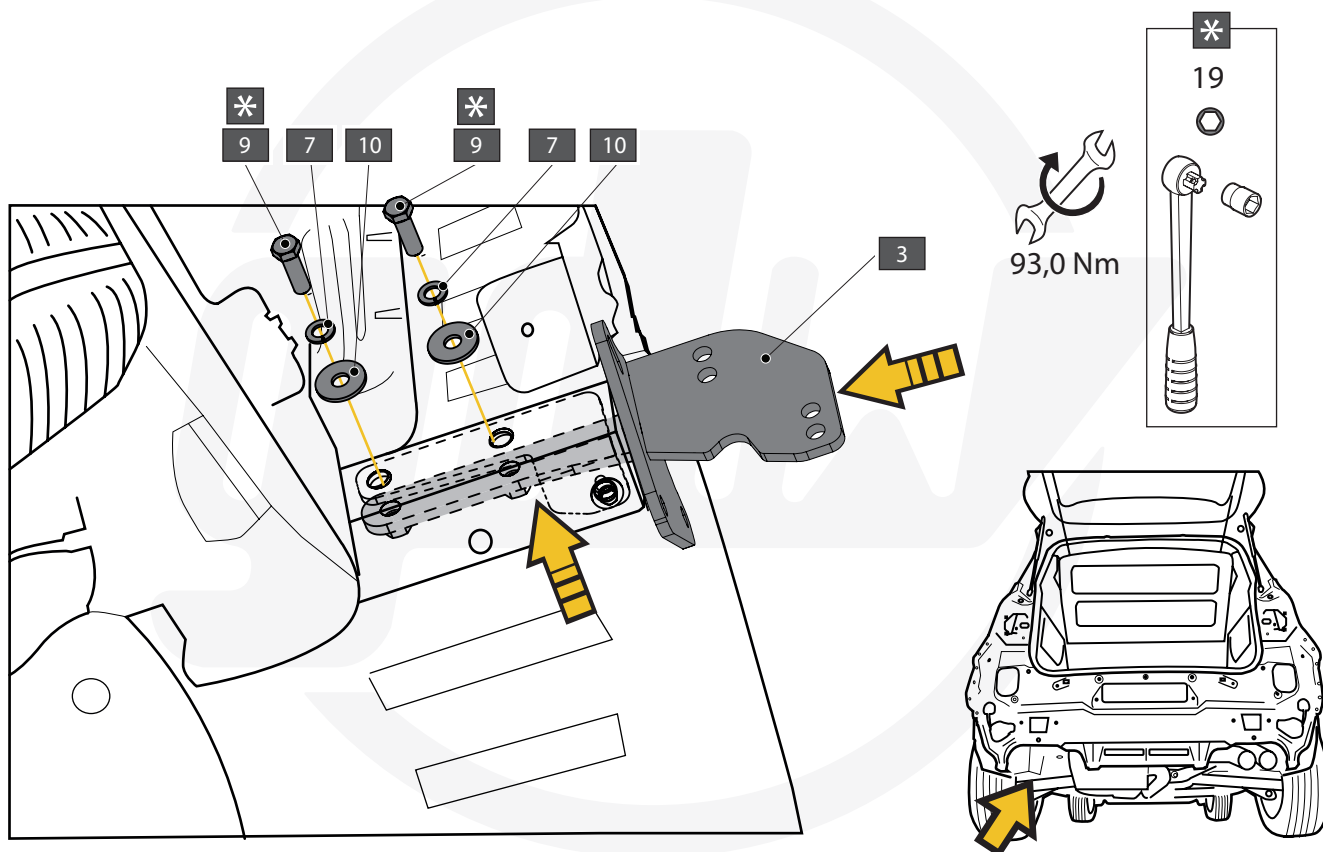
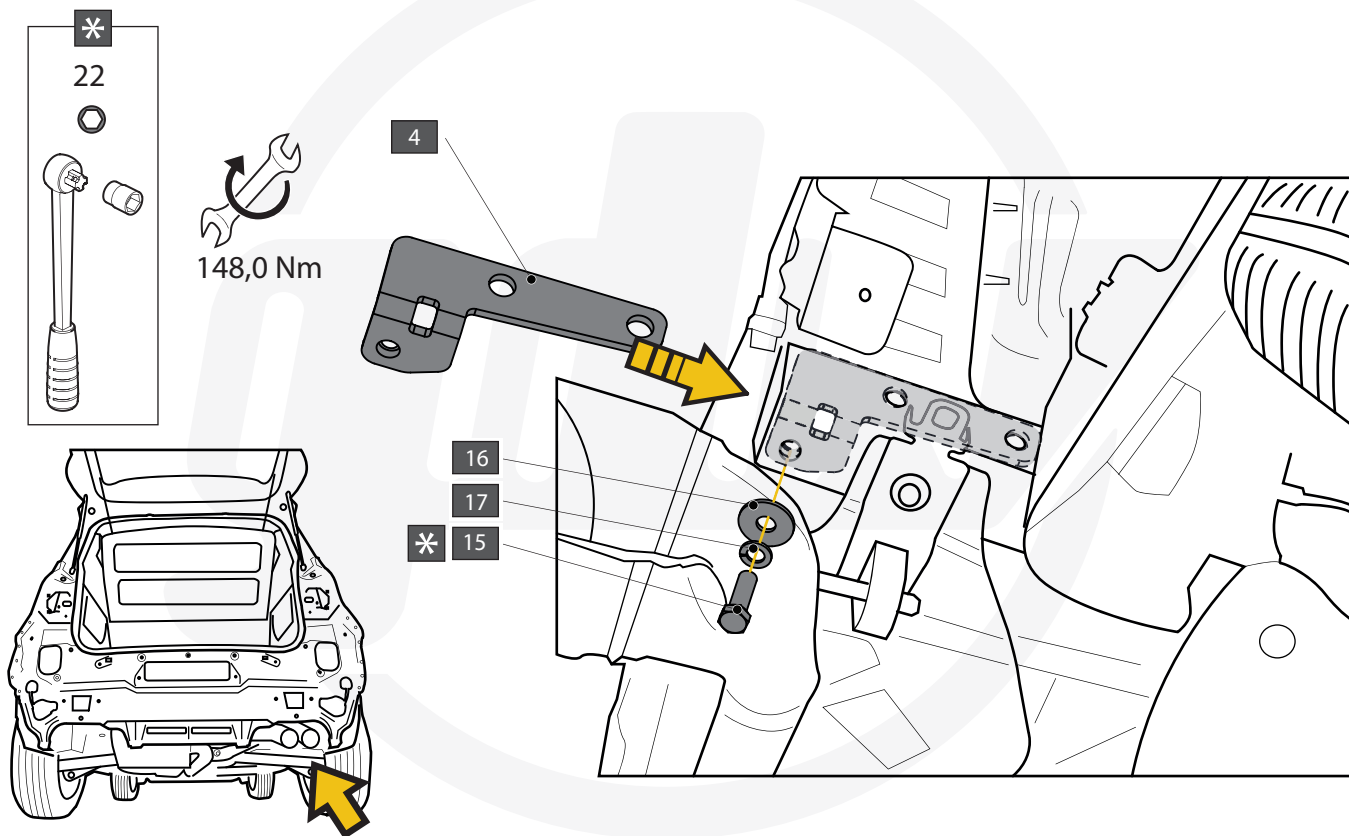



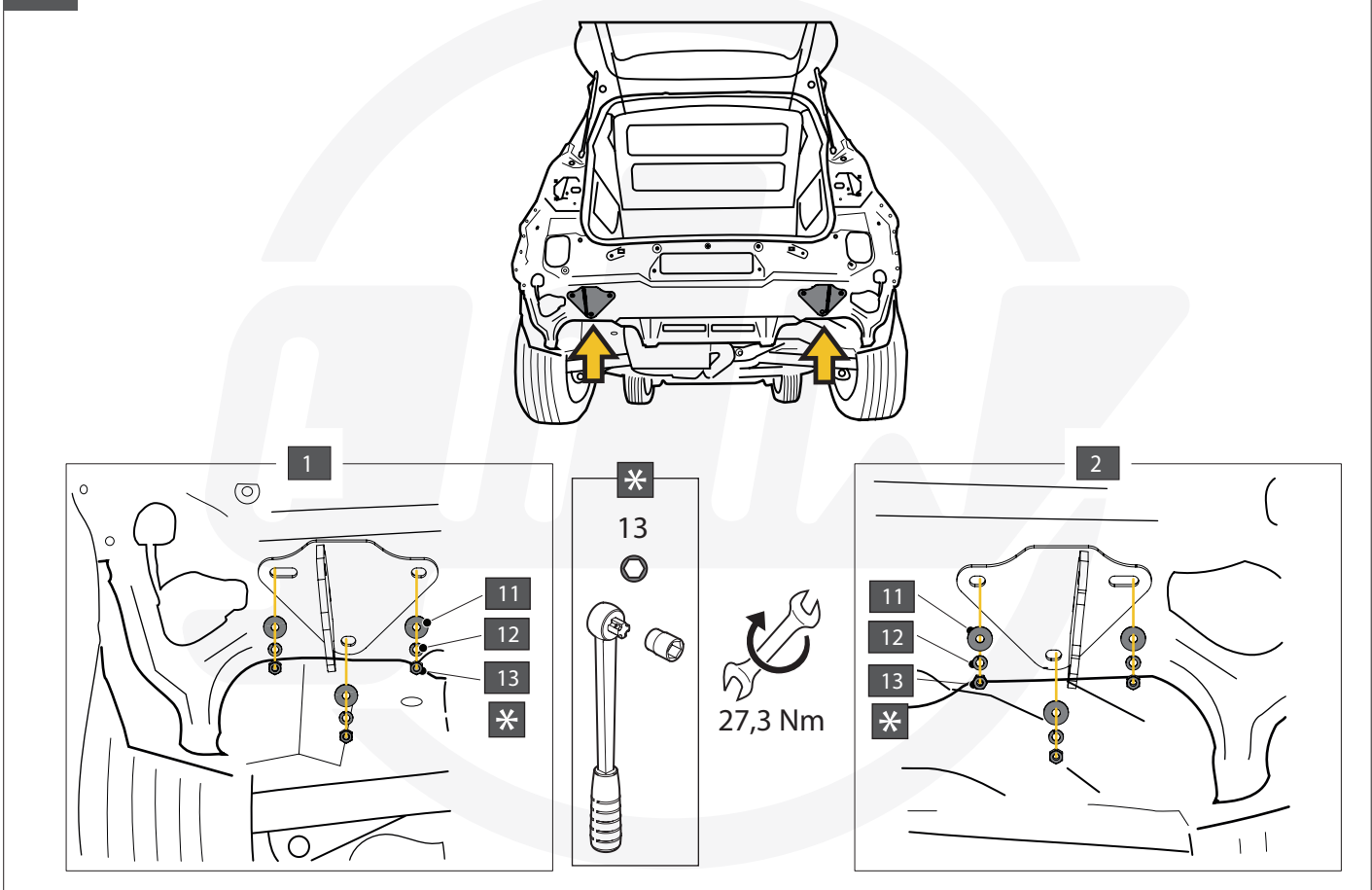
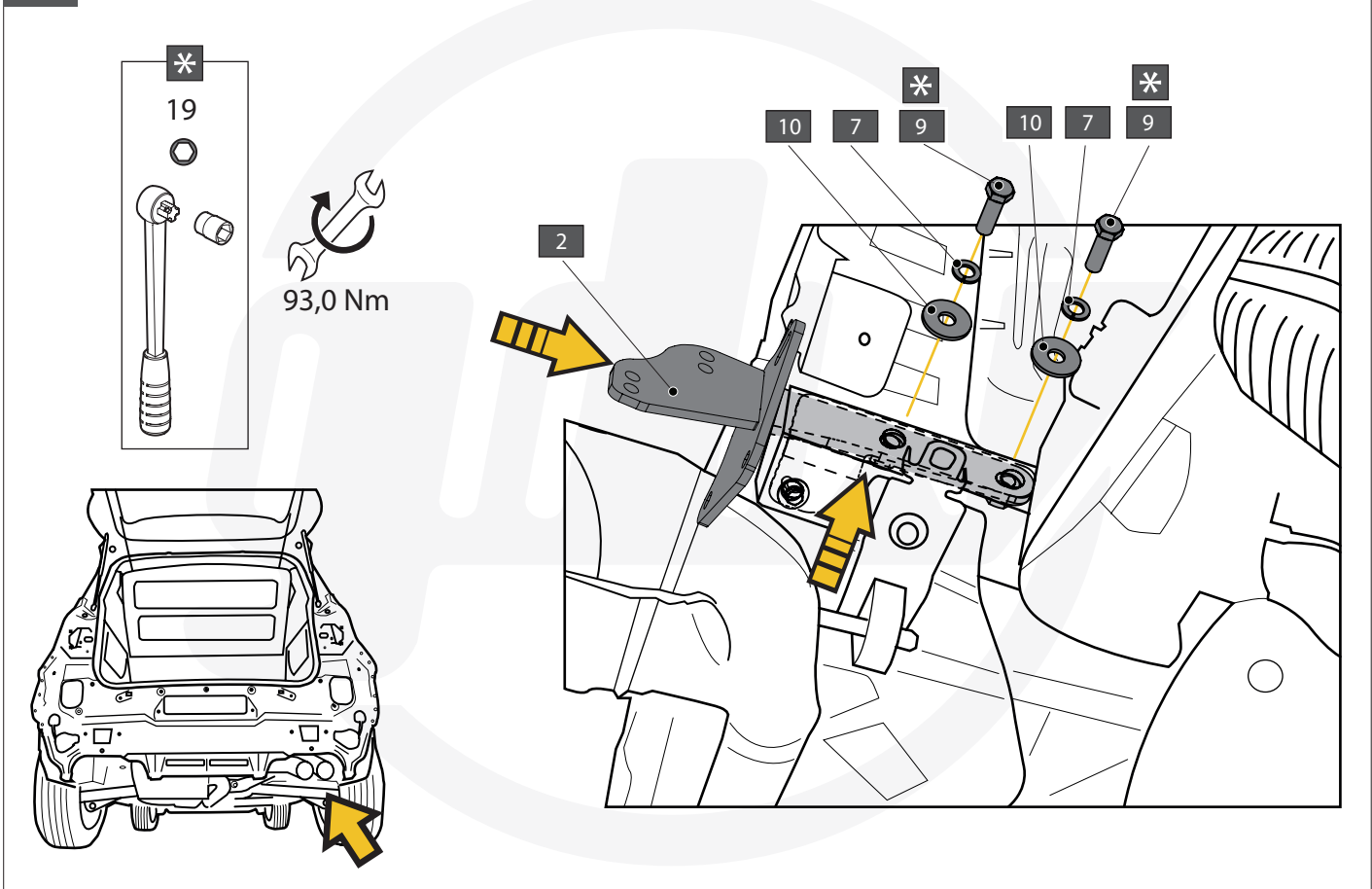

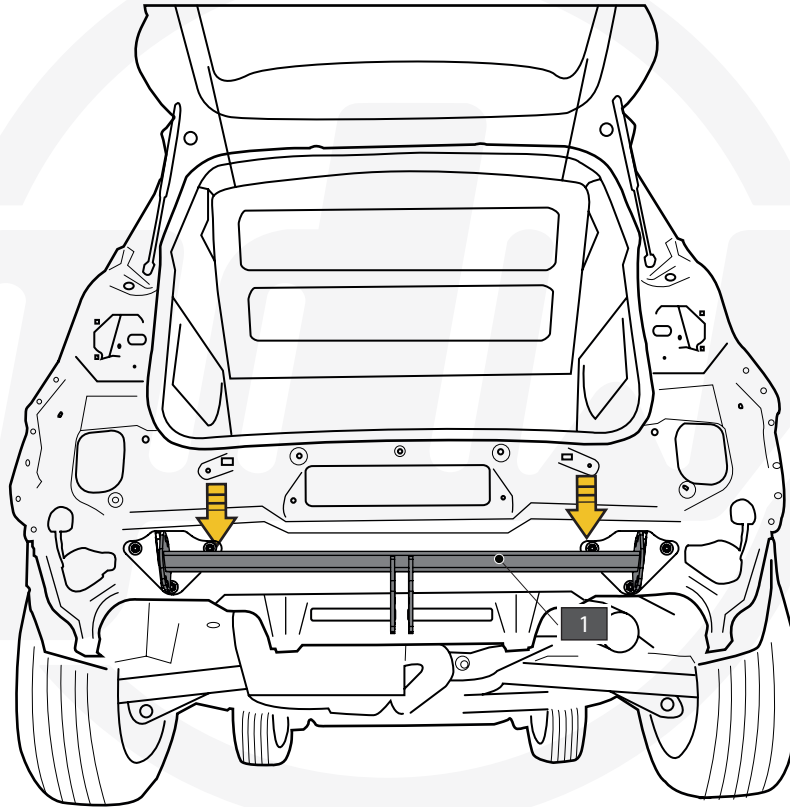

Jeep Renegade & Fiat 500 + 500X-Cross '15 - '18

Fiat Tipo 4D + Tipo 5D

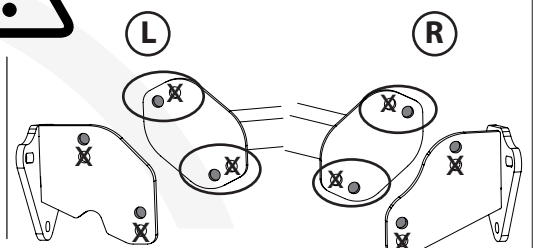
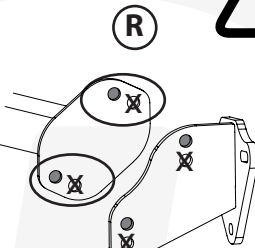
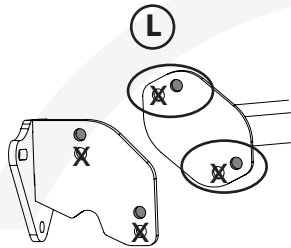
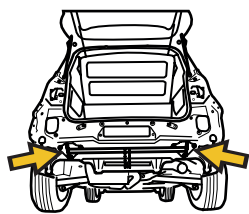

$X < 2 \text{ mm}$	$2 \leq X < 4 \text{ mm}$	$4 \leq X < 6 \text{ mm}$	$6 \leq X$

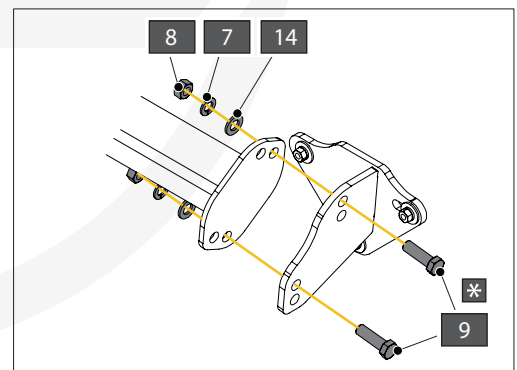
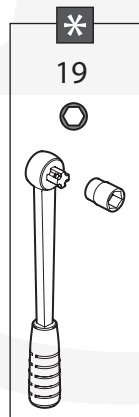
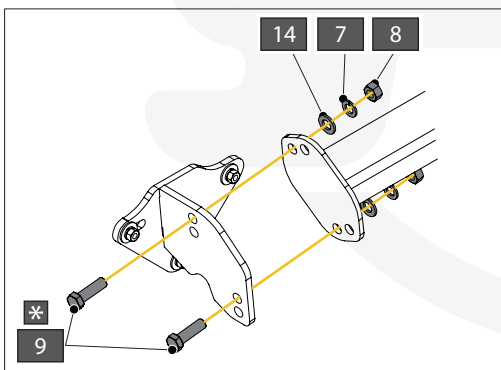

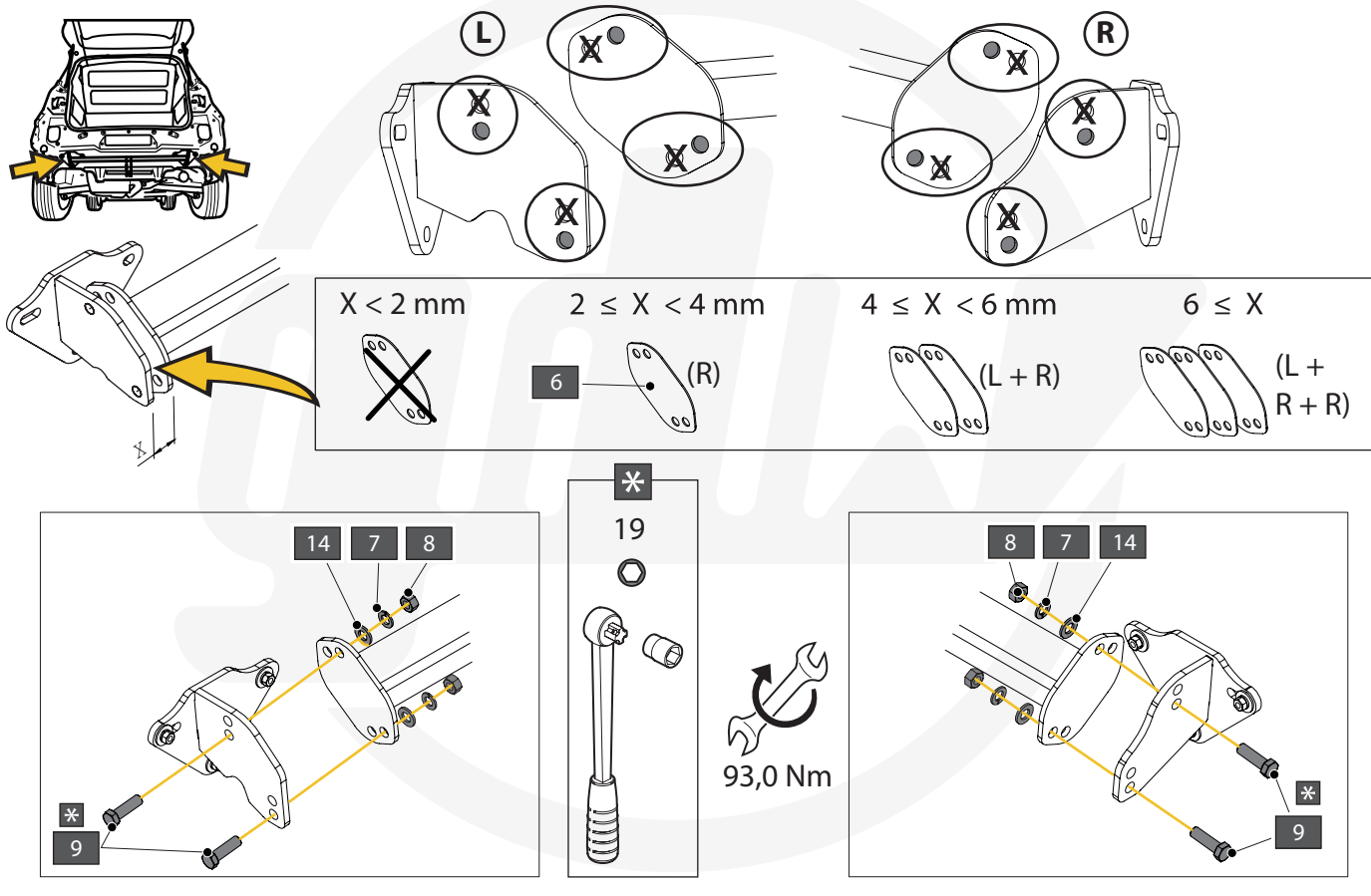

\* x7 DIN7337 4,8x16

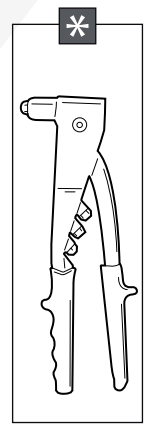
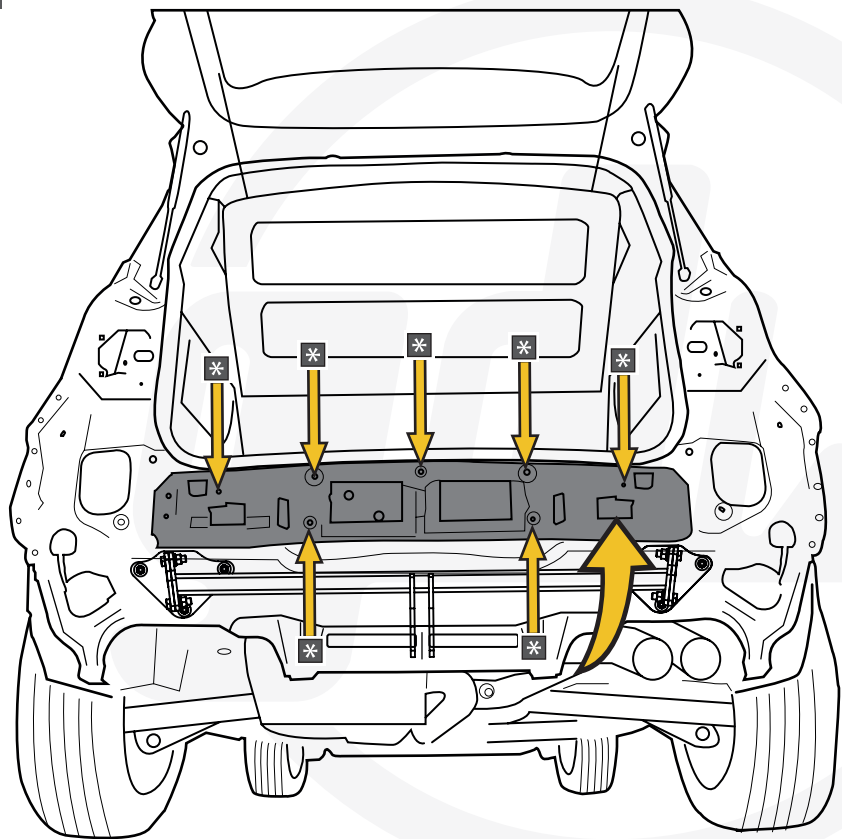

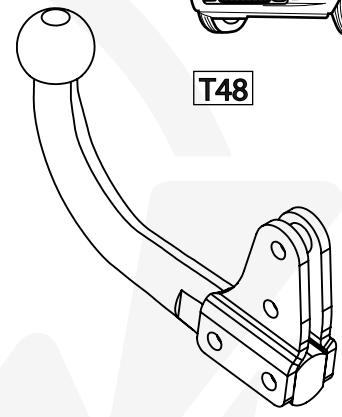
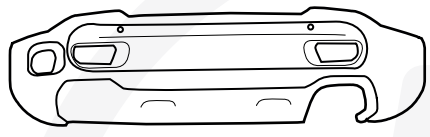

T48

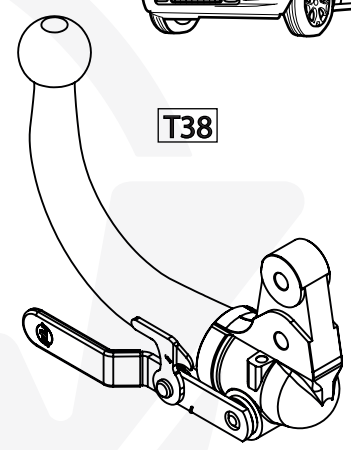
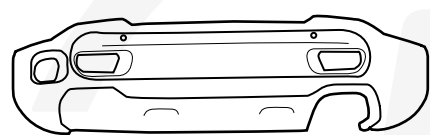
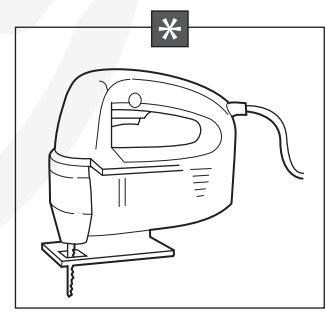
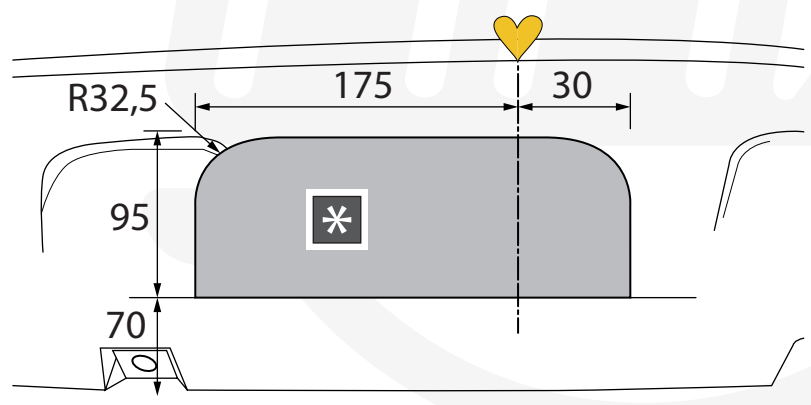

T38

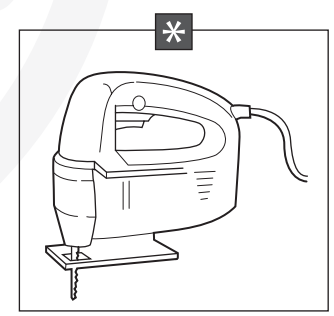
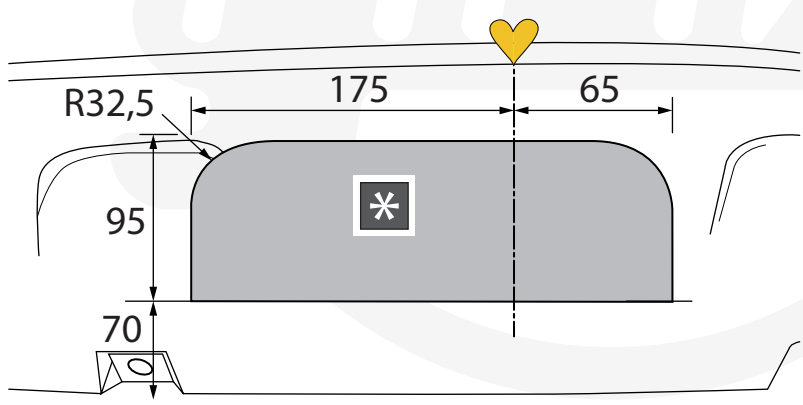



T48

T38

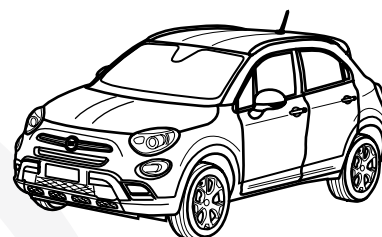
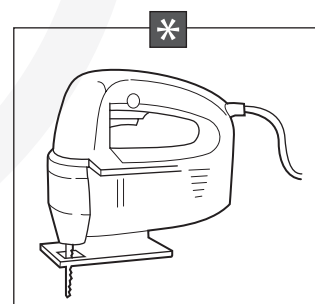
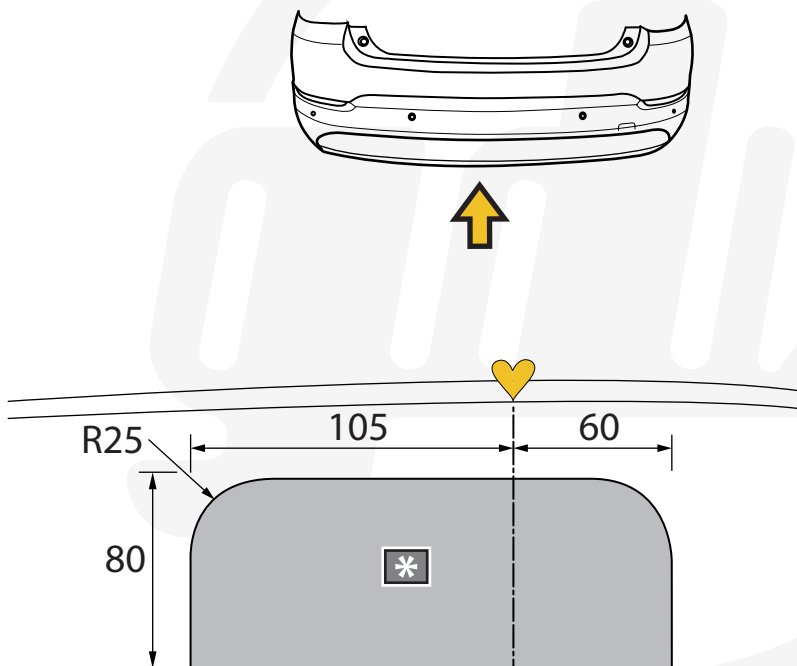
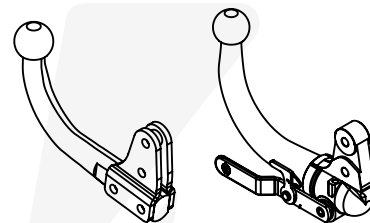

T48

T38

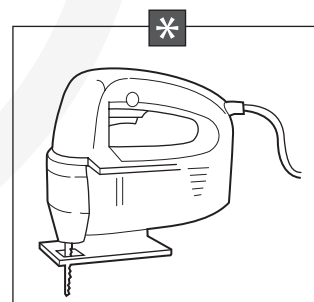
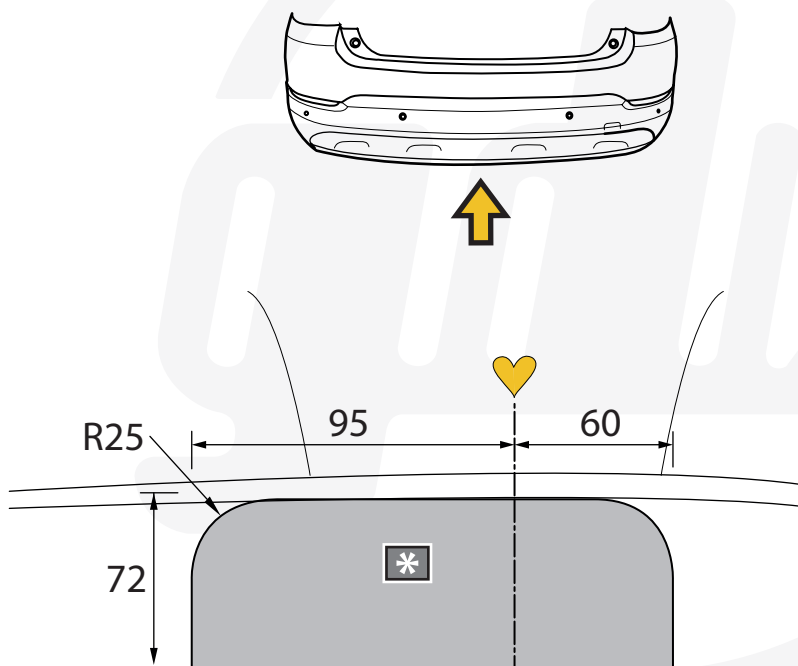
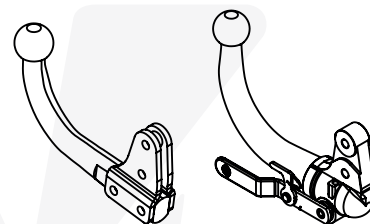

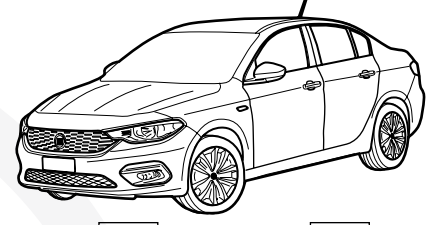
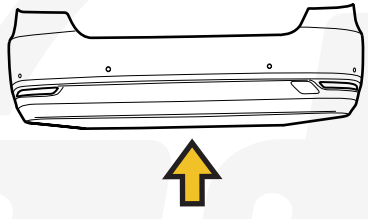

T48

T38

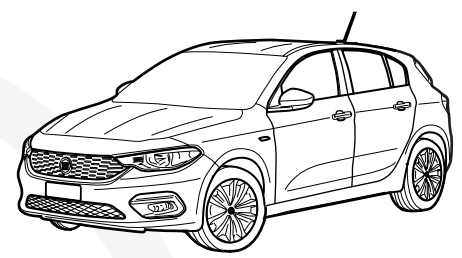
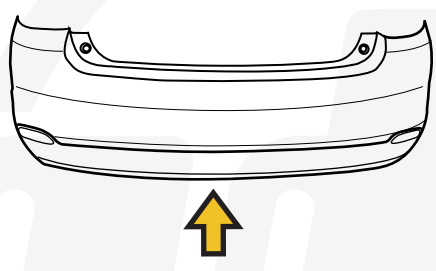
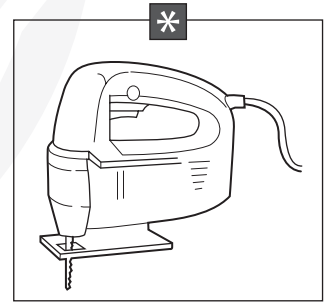
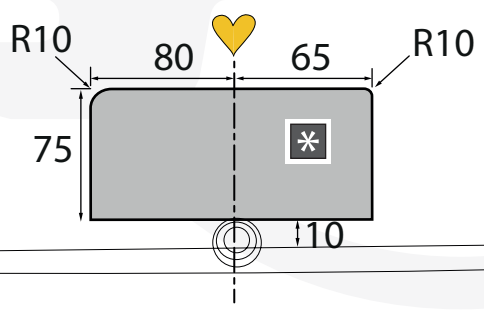
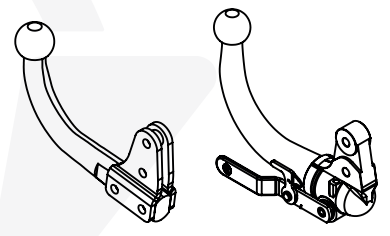

T48

T38

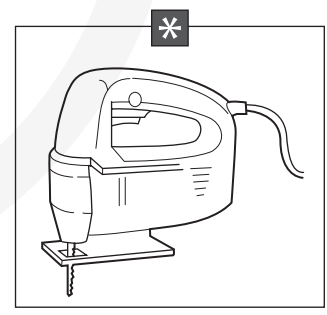
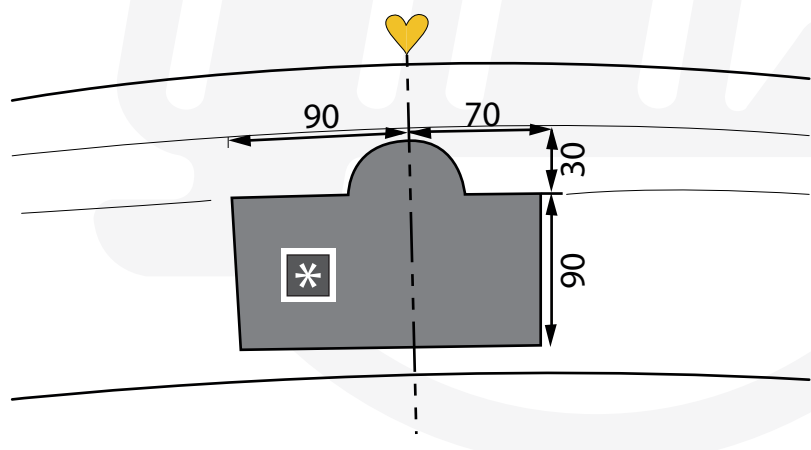
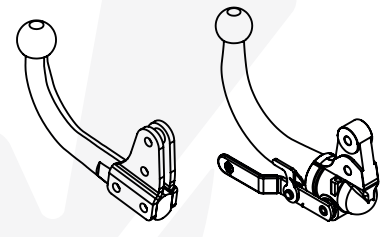

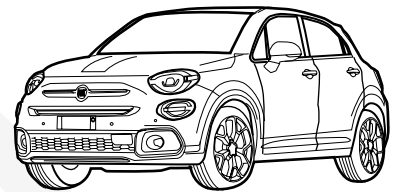
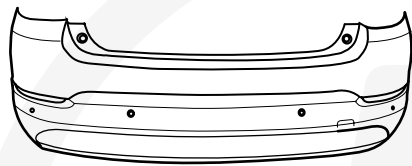

T48

T38

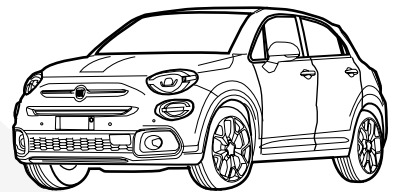
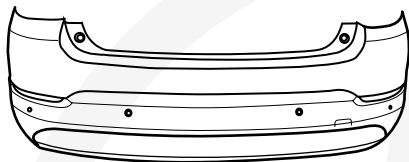
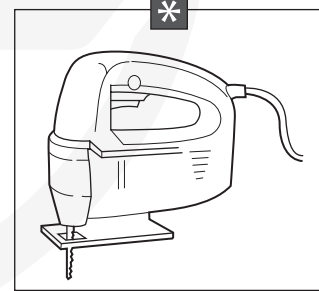
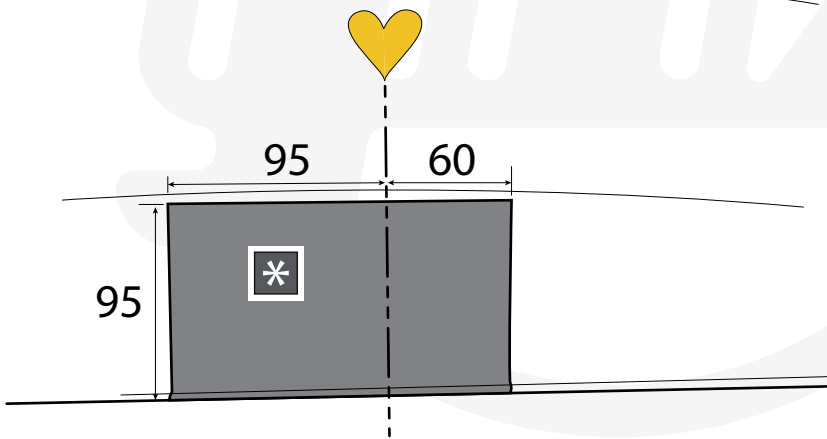
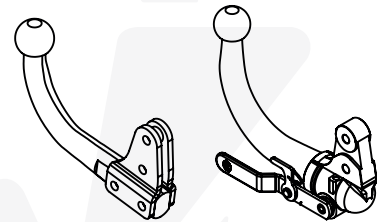

T48

T38

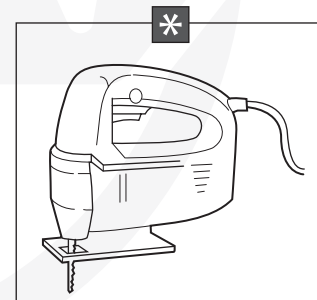
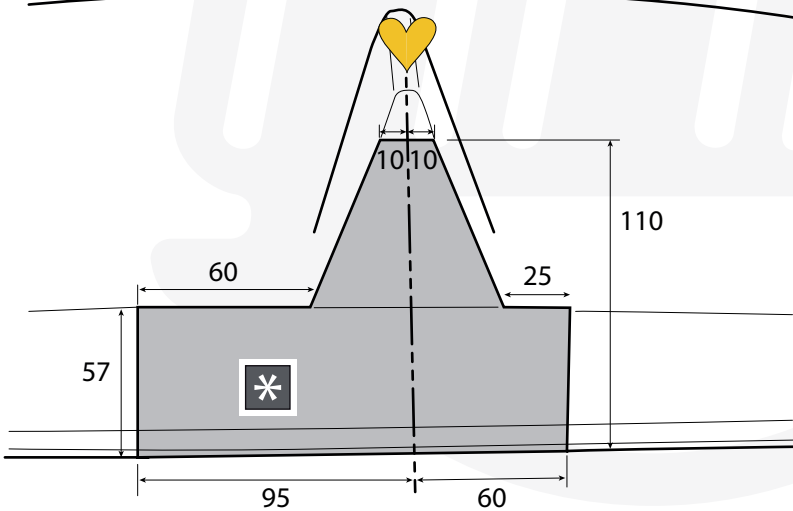
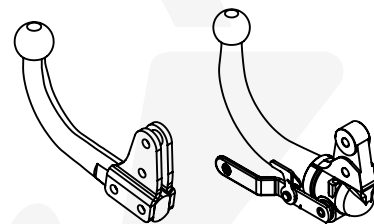



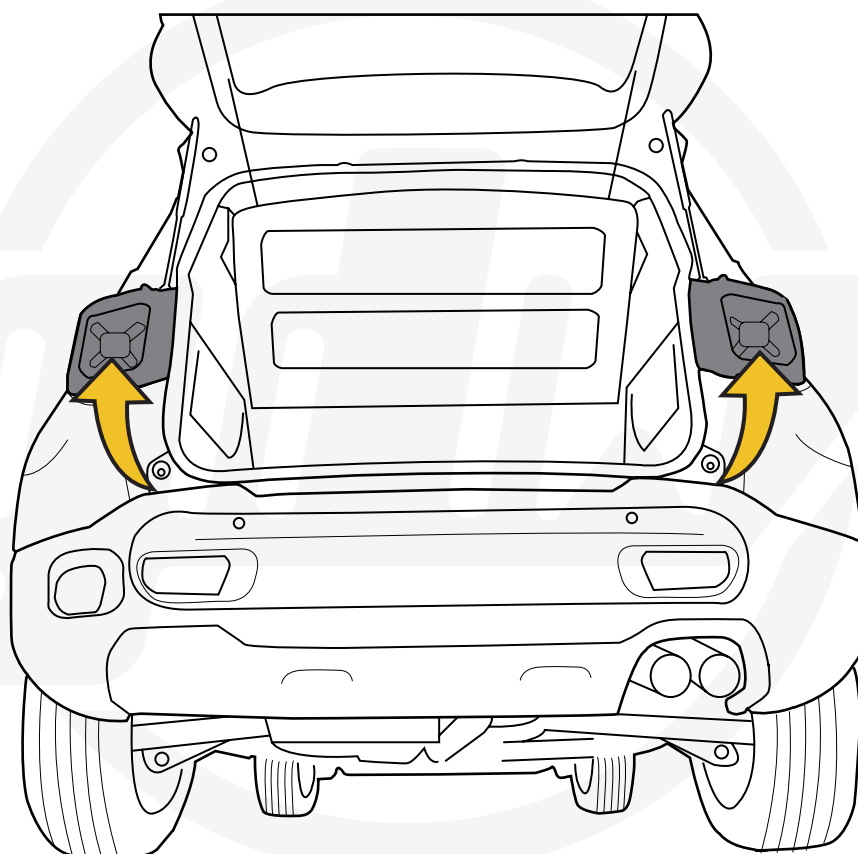
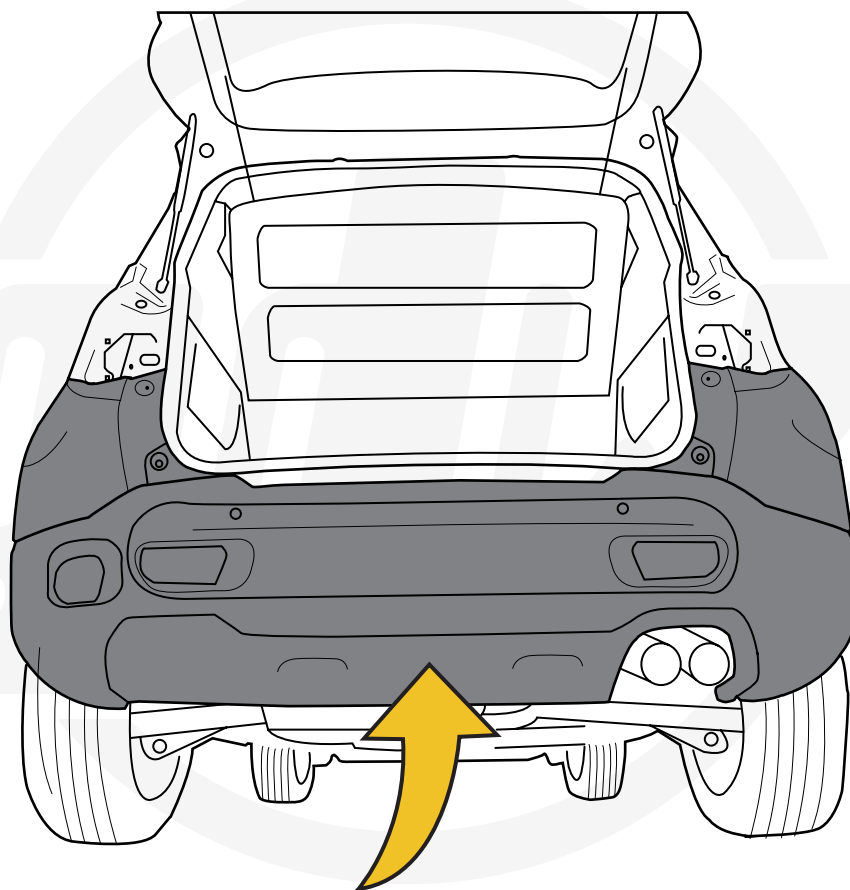

43 JEEP RENEGADE

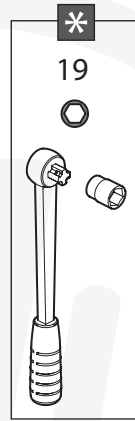
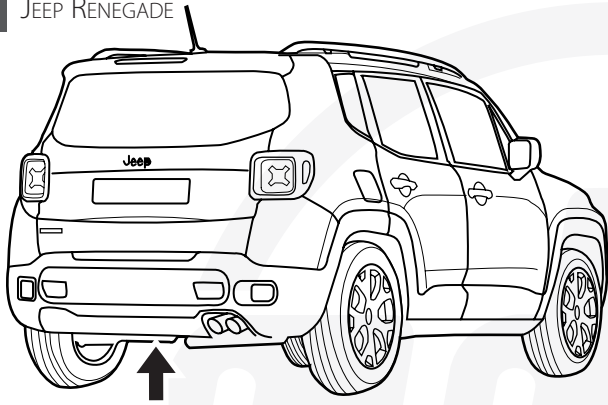

93,0 Nm

-P		X1	GDW REF. P07
B		X1	GDW REF. 900.025
C		X1	GDW REF. 900.026
D		X2	GDW REF. 900.011
E		X2	DIN931 M12 X 70
F		X2	DIN985 M12

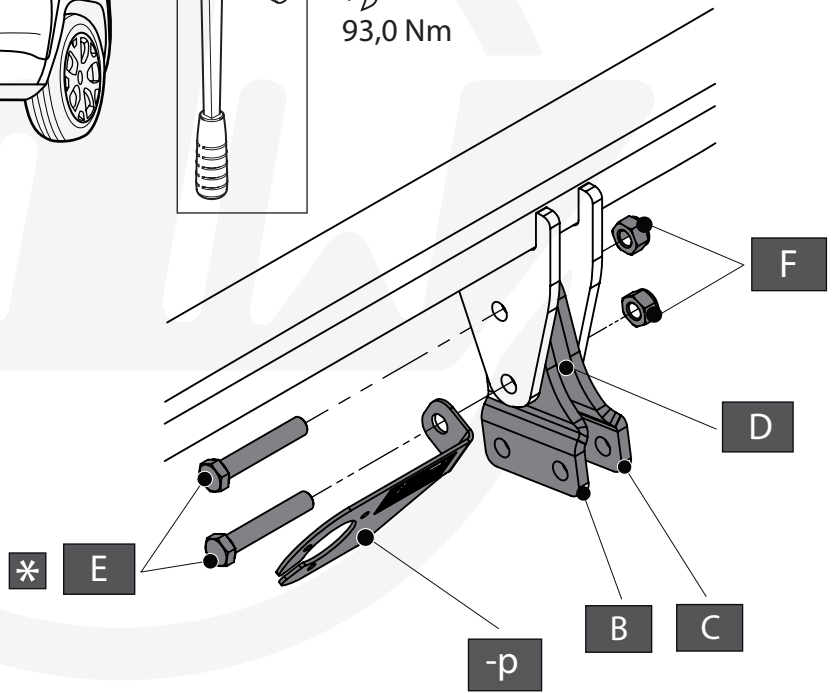

44 JEEP RENEGADE

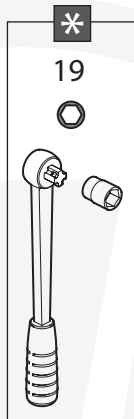
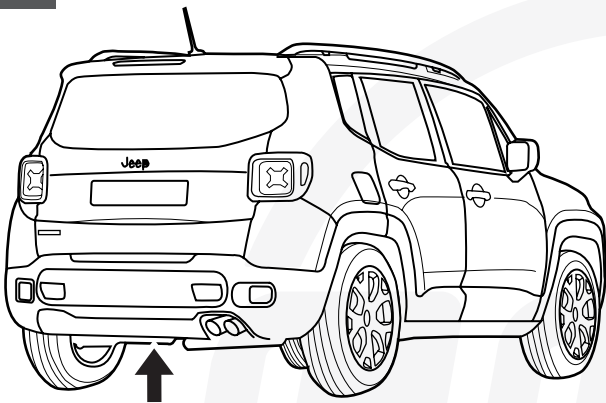

93,0 Nm

A		X1	944.H019
-S		X1	GDW REF. 900.053
E		X2	DIN931 M12 X 70
F		X2	DIN985 M12

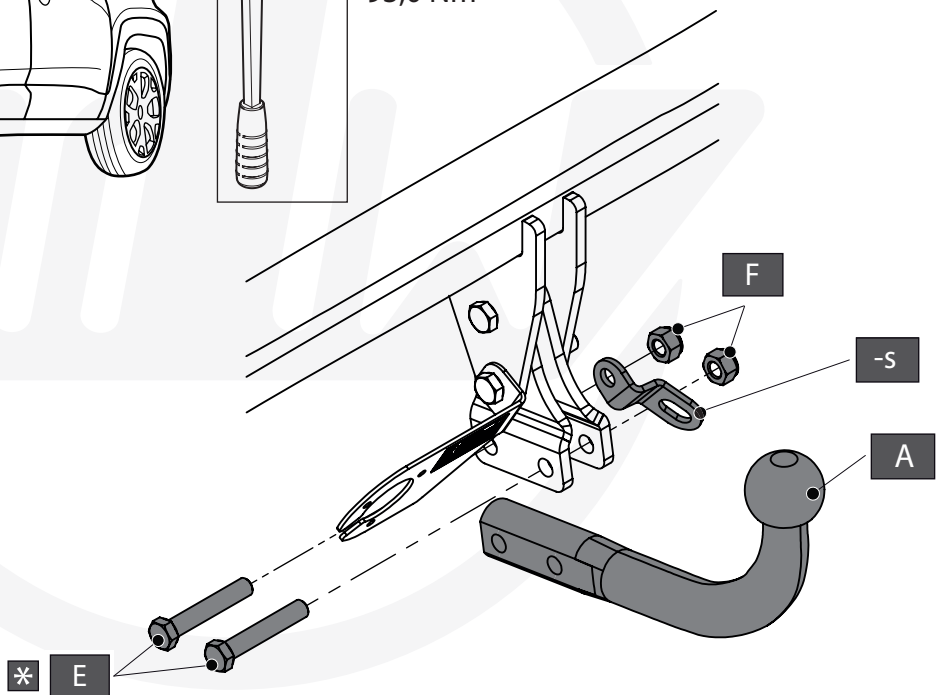

45 FIAT 500X / 500X-CROSS + FACELIFT / TIPO 4D + TIPO 5D /  
500X URBAN / 500X SPORT

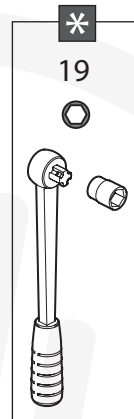
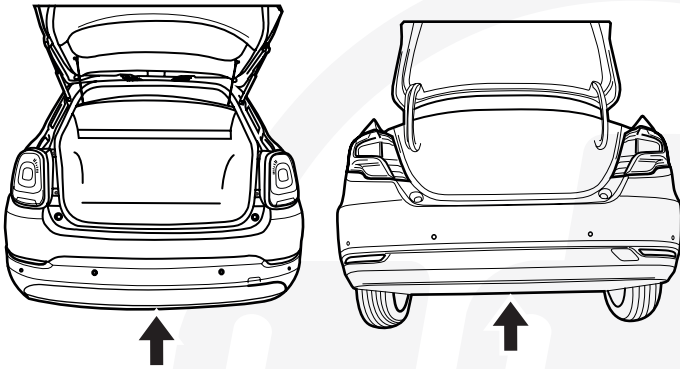

93,0 Nm

-P		X1	GDW REF. PO4
B		X1	GDW REF. 900.025
C		X1	GDW REF. 900.026
D		X2	GDW REF. 900.011
E		X2	DIN931 M12 X 70
F		X2	DIN985 M12

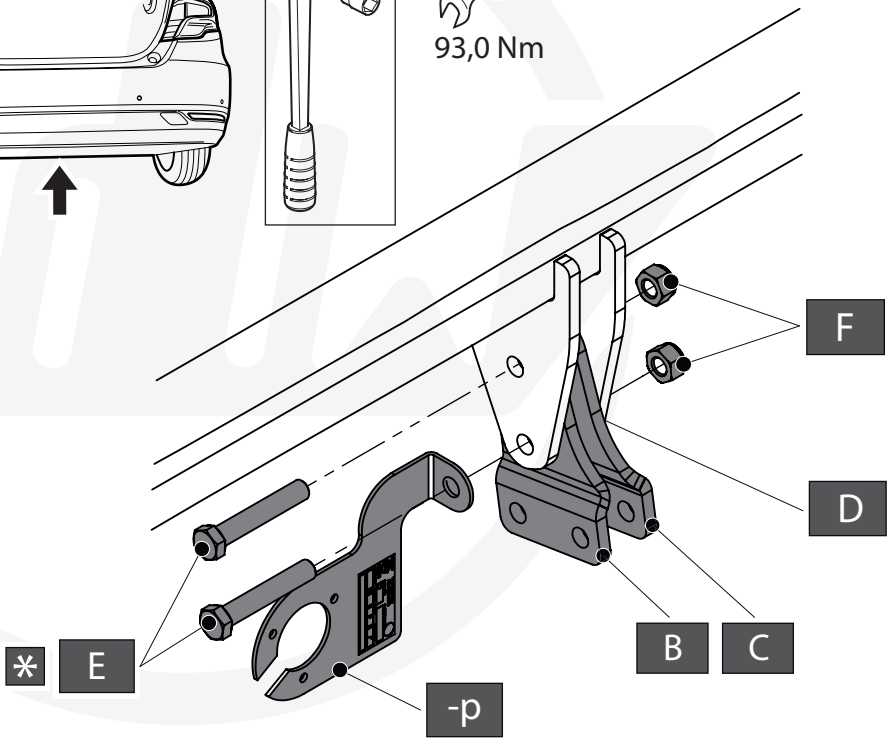

46 FIAT 500X / 500X-CROSS + FACELIFT / TIPO 4D + TIPO 5D /  
500X URBAN / 500X SPORT

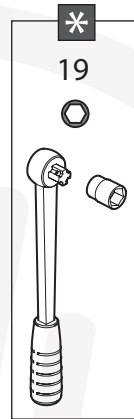
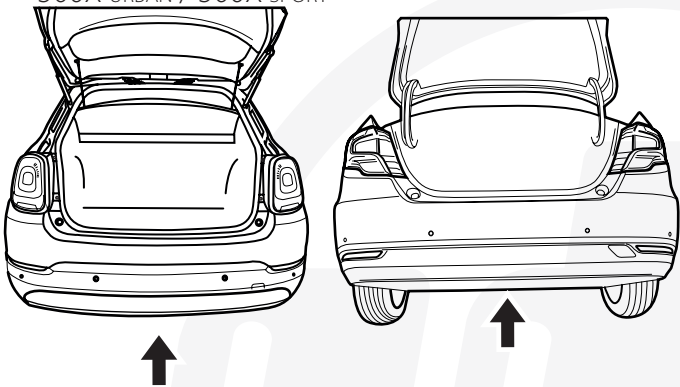

93,0 Nm

A		X1	944.H019
-S		X1	GDW REF. 900.053
E		X2	DIN931 M12 X 70
F		X2	DIN985 M12

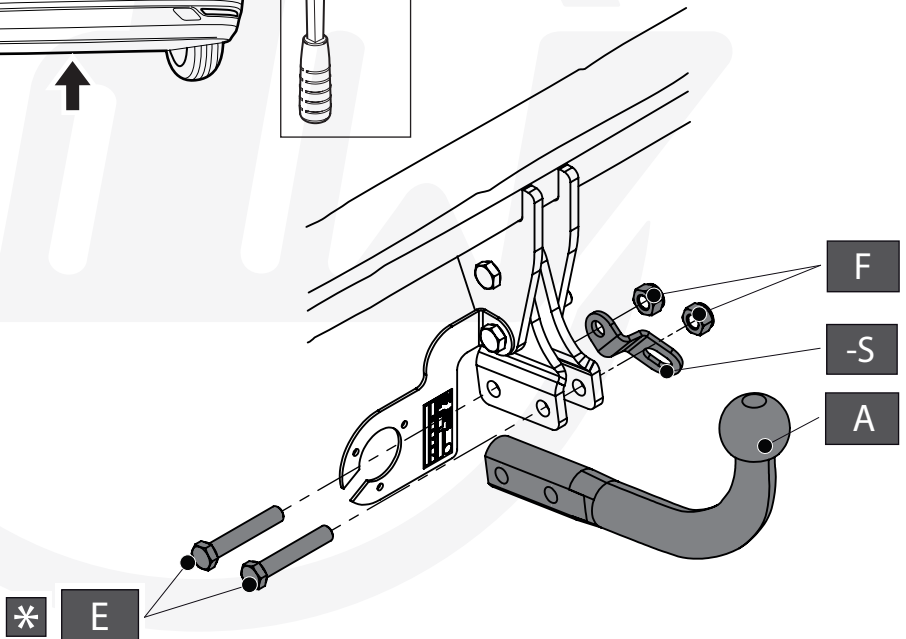

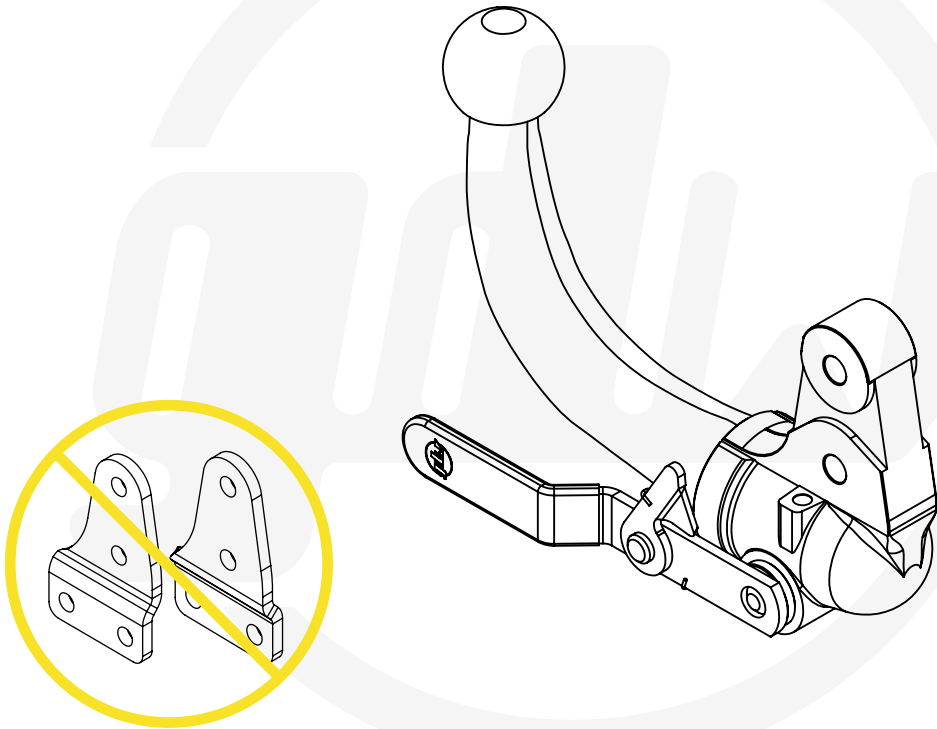

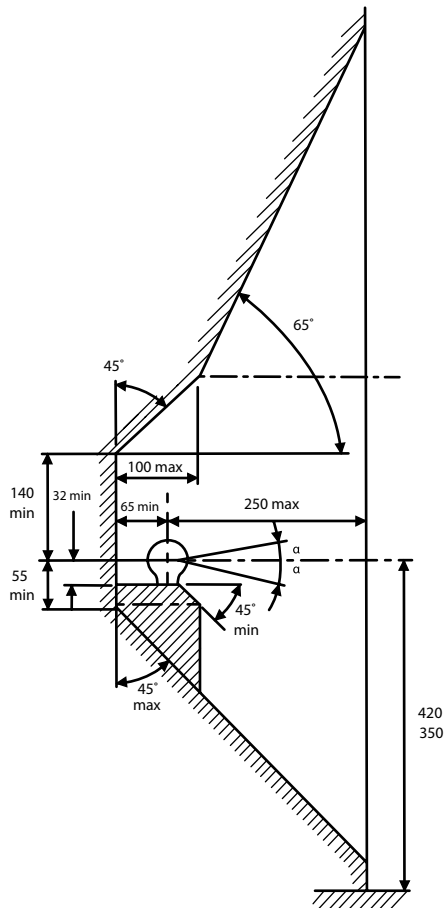

De tussenruimte conform bijlage VII, afbeelding 25 (a, b) van het reglement nr. 55-01 UN/ECE moet in acht genomen worden. Deze voorschriften zijn niet van toepassing op terreinvoertuigen klasse G.

La zone de dégagement doit être garantie conformément à l'annexe VII, illustration 25 (a, b) de la règle n° 55-01 UN/ECE. Ces dispositions ne s'appliquent pas aux véhicules tout-terrain classe G.

The clearance specified in appendix VII, diagram 25 (a, b) of regulation nr. 55-01 UN/ECE must be guaranteed. These requirements shall not apply to all-terrain vehicles class G.

Der Freiraum nach Anhang VII, Abbildung 25 (a, b) der Regulierung nr. 55-01 UN/ECE ist zu gewährleisten. Diese Vorschriften gelten nicht für Geländefahrzeugen Klasse G.

Revisar la imagen 25 (a, b) del suplemento VII según la regulación nr. 55-01 UN/ECE

Spazio libero garantito intorno alla sfera, di cui all'allegato VII, disegni 25 (a, b) del Regolamento n. 55-01 UN/ECE.

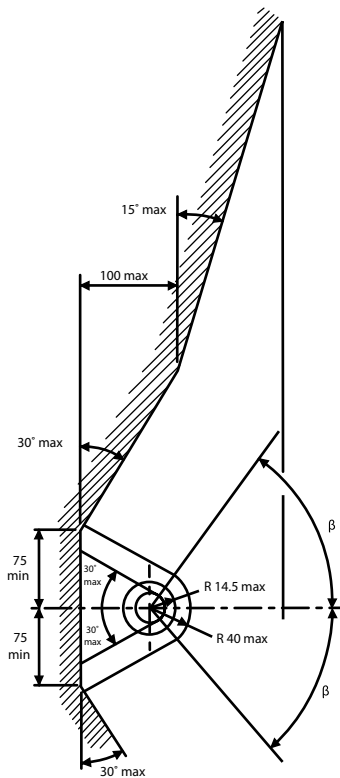

Bij toelaatbaar gewicht van het voertuig

Pour poids total en charge autorisé du véhicule

At laden weight of the vehicle

Bei zulässigem Gesamtgewicht des Fahrzeuges

Peso total admisible del vehículo

Ved tilladt samlet vægt for køretøjet

Peso totale ammissibile del veicolo