



Installation Instructions: Electrical System for Towing Hitch

General Data

Part number		Vehicle
Westfalia	Vehicle Manufacturer	
321 534 300 143	--	VW Passat B6 Limousine RHD 13p. ≥MY08
321 535 300 143	--	VW Passat B6 Variant RHD 13p. ≥MY08
321 534 300 147	--	VW Passat B6 Limousine RHD 7p. ≥MY08
321 535 300 147	--	VW Passat B6 Variant RHD 7p. ≥MY08

Constant plus extension kit for the 13-pin socket

► **Note**

The constant plus extension kit allows a charging lead for a booster battery to be used.

Part Number		Vehicle
Westfalia	Vehicle Manufacturer	
300 025 300 113	--	all vehicles

Important Notes

Read the installation manual prior to starting work.

The electrical kit should only be installed by qualified personnel.

Follow guidance in the current repair manual when carrying out installation work on the vehicle.

The ESP control unit must be recoded for activation of the trailer stabilisation system (>MY07).



Caution – Disconnect the battery!

Danger of damage to the vehicle's electronic system. Data which are stored electronically may get lost.

Read out the fault storage prior to starting work.

Note

During installation special attention has to be paid to the following points:

- Cables must not be pinched or damaged.
- All sealing elements have to be installed properly.
- The socket gasket has to be positioned on the insulating sleeve and not on the individual wires.
- Lay the cables such that they do not rub on the vehicle and are not bent.
- Do not lay any cables near the exhaust system.

Failure of a trailer light (also direction indicator lamps, but not back-up light or rear fog lamp) is indicated by the light failure monitoring system on the combination instrument. There is no additional indicator light (C2) for monitoring the direction indicators on the trailer in the vehicle.

When a trailer is used, the rear fog lamp of the traction vehicle is deactivated.

In the case of trailers without rear fog lamp, a rear fog lamp has to be retrofitted.

A socket adapter may only be used in conjunction with a trailer. When the trailer is no longer used, remove the socket adapter.

Correct trailer operation has to be checked using a trailer or a test instrument with load resistors.

Subject to technical alterations!

Installation Overview Variant

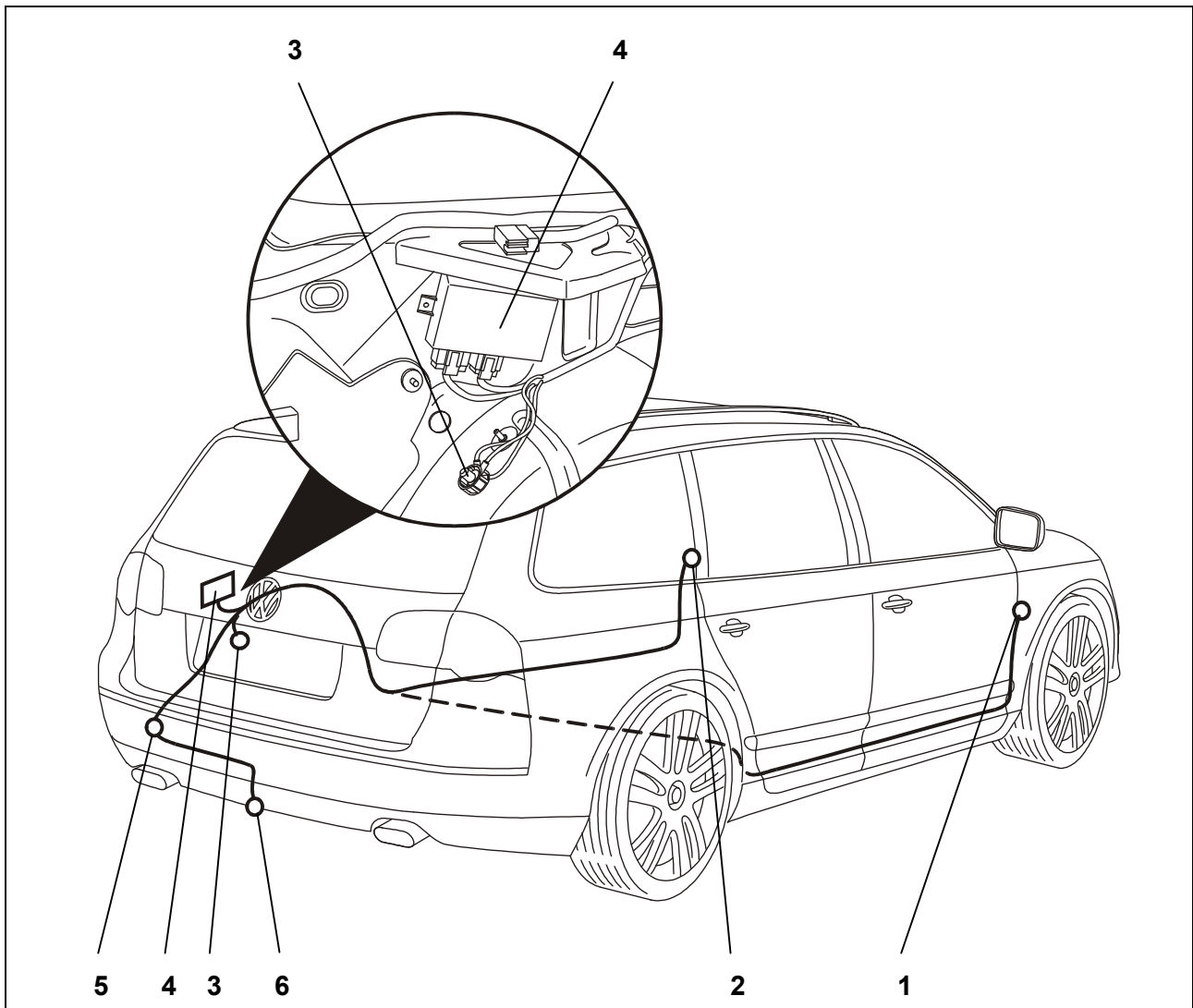
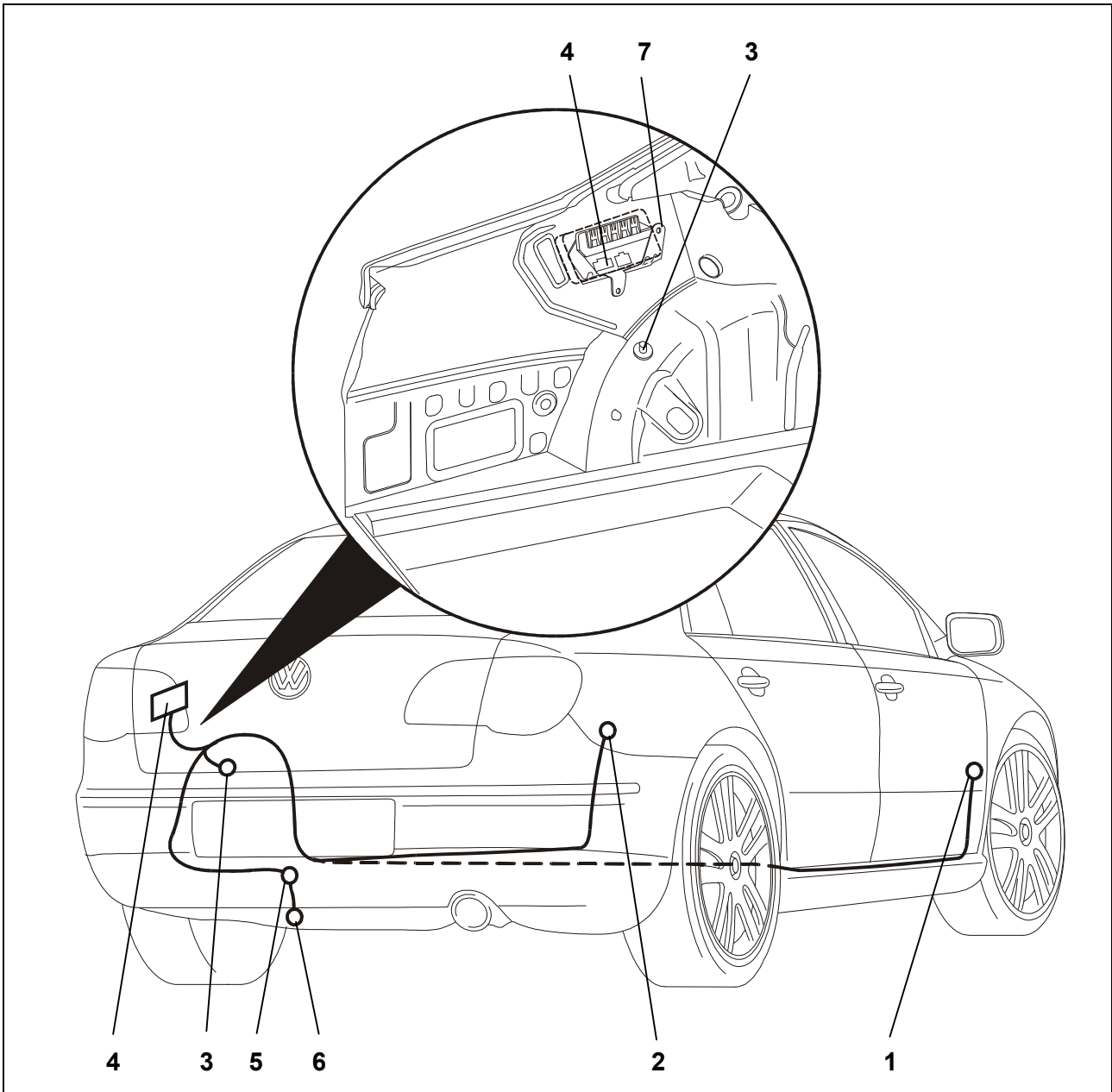

Fig. 1: Installation overview

- | | |
|--|---------------------------|
| 1 Control unit for vehicle electrical system | 4 Trailer connection unit |
| 2 Fuse box | 5 Hole for cable |
| 3 Ground point | 6 Trailer socket |

Installation overview Limousine**Fig. 1: Installation overview**

- | | |
|--|-------------------------------------|
| 1 Control unit for vehicle electrical system | 5 Hole for cable |
| 2 Fuse box | 6 Trailer socket |
| 3 Ground point | 7 Mount for trailer connection unit |
| 4 Trailer connection unit | |

Install electrical kit

1. Disconnect negative terminal of battery.
2. Remove the following covers and panelling, as necessary:
 - In the boot
 - Boot floor cover
 - Loading sill cover
 - Panelling on the left-hand side of the boot
 - On the left/right side of the vehicle
 - Seats of the rear bench seat
 - Left and right scuff plates
 - Right panelling by the steering column
 - Left fuse box cover
3. Remove cover from the 40 mm hole below the left tail light in the vehicle tail end panel (Fig. 1/5).
4. Using the M6 screws provided, secure the trailer connection unit to the mounting plate supplied (only Limousine, Fig. 1/7)
5. Fix trailer connection unit in the space provided on the left-hand side of the boot using the spring nuts and fixing screws provided (Fig. 1/4)
6. Route the end of the cable with the 16-pin plug and eyelet from outside through the hole to the trailer connection unit (Fig. 1/4).
7. Insert the rubber grommet in the hole (Fig. 1/5).
8. Route the end of the cable set with the socket to the socket mounting plate (Fig. 1/6).

Fit socket

9. Push contact insert into the socket housing and slide rubber seal up to the socket.
10. Screw the socket onto the mounting plate with the screws provided (Fig. 1/6), torque setting: max. 2.0 Nm. If necessary shorten screws.

► Note

Together with a detachable tow bar:

Cable outlet must be at 12 o'clock when the socket is in its operational position!

Connect trailer connection unit

11. Connect and lock the 16-way socket housing to the socket provided on the trailer connection unit (Fig. 1/4).
12. Connect and lock the 12-way socket housing of the 9-core cable set to the socket provided on the trailer connection unit.

Install electrical kit

13. Connect the brown wires with eyelets to the ground point on the vehicle (Fig. 1/3).
14. Route the 9-core cable set over the left wheel housing up to the rear bench seat.
15. Route the 6-core cable set across from left to right and along the existing cable looms / cable ducts on the driver's side up to the control unit for the vehicle electrical system in the driver's footwell (Fig. 1/1).
16. Route the 3-core cable set alongside the existing cable looms / cable ducts to the fuse box at the front left (Fig. 1/2).
17. Slide open the red catch on the control unit for the vehicle electrical system (Fig. 1/1), pull of the black 12-pin plug (socket G) and open the catch. Release the following wires and insert in the 3-pin black socket housing on the cable set:
 - Orange/brown wire from chamber 7 into chamber 1.
 - Orange/green wire from chamber 8 into chamber 3.
18. Insert the orange/brown and orange/green wires from the cable set, according to colour, into the freed chambers 7 and 8 of the 12-pin plug.
19. Close catches and re-connect plug to the vehicle electrical system control unit.
20. Pull out the black 16-pin plug (socket E) from the vehicle electrical system control unit and open the catch. Release the following wire and insert into the 3-pin white socket housing on the cable set:
 - Black/red wire from chamber 2 into chamber 2.
21. Insert the black/red wire from the cable set into the freed chamber 2 of the 16-pin plug. Close catch.
22. Re-connect plug to the vehicle electrical control system and close red catch.
23. In each case, plug the open 3-pin black and white housings together.
24. Remove black cover from fuse box (Fig. 1/2) and slide open the purple catch. Insert the following wires into the fuse-protected side of the fuse chambers as indicated:
 - Black/blue wire into chamber 6
 - Red/black wire into chamber 29 (> MY2006), in 28 (MY2007 >)
 - Red/blue wire into chamber 30 (> MY2006), in 38 (MY2007 >)
25. > MY2006: If fuse positions 29 - 31 on the vehicle have not been pre-equipped with terminal 30, the wire adapter (supplied) must be used.
Insert the 2-way contact into input side of sockets 29 - 30 of the fuse box.
Connect the contact with double lug to the free contact of the bridge fuse for fuses 32-37.
26. MY2007 >: If the fuse positions 28 + 38 of the vehicle are not equipped with terminal 30, the provided wire adapter must be inserted.
Insert the wire ends as follows:
 - The red/black wire into the still free slot of fuse 28
 - The red/blue wire into the still free slot of fuse 38
Plug the contact with the double stop on the connecting lug of fuse bridge 32-37.
27. Close the purple catch on the fuse box and push on the black cover.
28. Insert the 5A fuse in fuse position 6 and the 15 A fuse in fuse positions 29 and 30 / 28 and 38.

29. For 13-pin trailer socket only:

The functions "permanent plus", "charging lead" and "charging lead ground" can be retrofitted using the 3-pin constant plus preparation plug, Westfalia order-no. 300 025 300 113.

Check operation

30. Re-connect ground of vehicle battery.

31. A V.A.G Service Tester must be used to code the vehicle's Gateway with the additional function for the towing hitch, as follows:

- Vehicle self-diagnosis
 - o 19 diagnostics interface for data bus
 - long code read/write
 - 69 trailer function (code)

32. On vehicles with park distance control (PDC), the PDC control unit must be coded as follows:

- Vehicle self-diagnosis
 - o 76 park distance control
 - 07 code control unit
 - change the fifth decimal place from the right from "0" to "1"

33. Switch off ignition, remove ignition key, wait 1 minute, switch on ignition.

34. > MY07: To activate the trailer stabilisation system, the control unit for the brake electronics must be recoded:

- Vehicle self-diagnosis
 - o 03 brake electronics
 - o Read out and record the current code for the brake electronics on the white sticker provided
 - 07 code control unit
 - new code = old code + 16384
 - record the new code also on the sticker provided
 - 03 actuator diagnosis
 - press "next", ⇒ brake lights on the vehicle are activated
 - cancel actuator diagnosis
 - Stick the sticker in the "1.1 Service Plan" booklet in section "Additional entries by the workshop"

35. > MY07: Switch off ignition, remove ignition key, wait 1 minute, switch on ignition.

36. > MY07: Check / amend the code of the parking brake control unit

- Vehicle self-diagnosis
 - o 53 parking brake
 - vehicles without Autohold function: code 11
 - vehicles with Autohold function: code 12
 - 07 code control unit
 - o enter the code according to the vehicle fittings (with/without Autohold)

37. Check the operation of the trailer using suitable test equipment (with load resistances) or with a trailer.
38. Secure all cables with cable ties.
39. Re-fit all disassembled parts.

Socket allocation

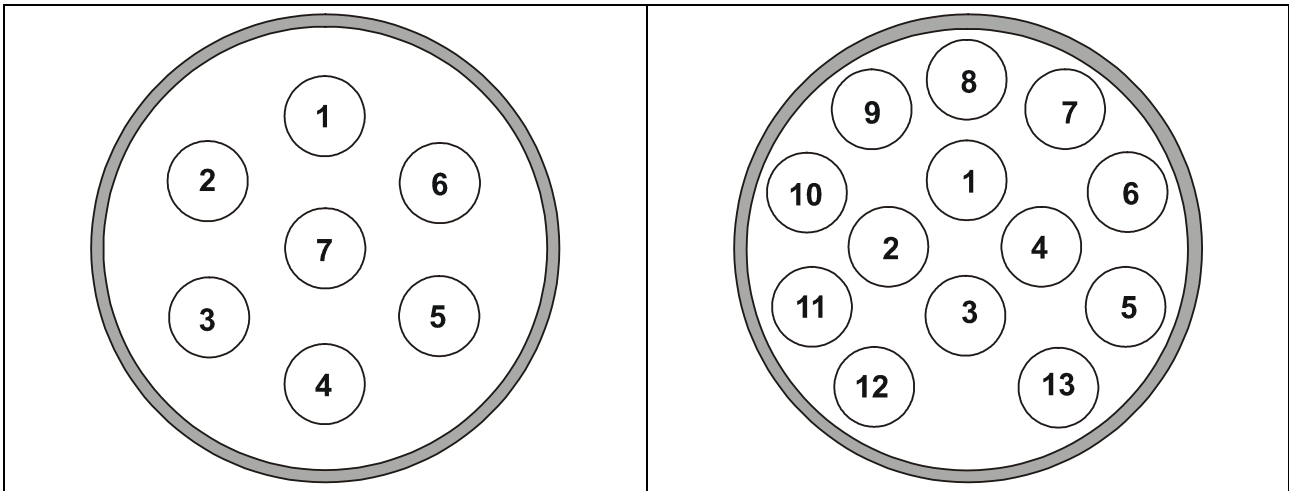

Contact	Circuit	Cable colour
1	Turn signal indicator, left	black/white
2	Rear fog light	grey/blue
3	Ground (circuit 1-7/8)	brown
4	Turn signal indicator, right	black/green
5	Tail light, right	grey/red
6	Brake light	black/red
7	Tail light, left	grey/black
8	<i>Back-up light</i>	<i>black/blue</i>
9	<i>Constant plus</i>	<i>red</i>
10	<i>Charging line</i>	<i>yellow</i>
11	<i>Ground (circuit 10)</i>	<i>brown/white</i>
12	<i>Trailer identification</i>	--
13	<i>Ground (circuit 9)</i>	<i>brown</i>