

Fitting instructions

Make: Renault

Megane Sedan / CC; 2003->

Type: 4263

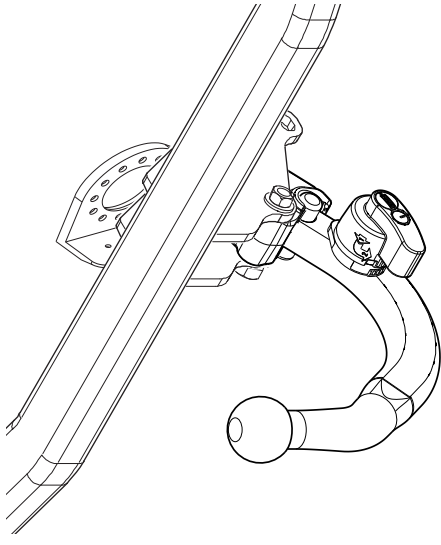
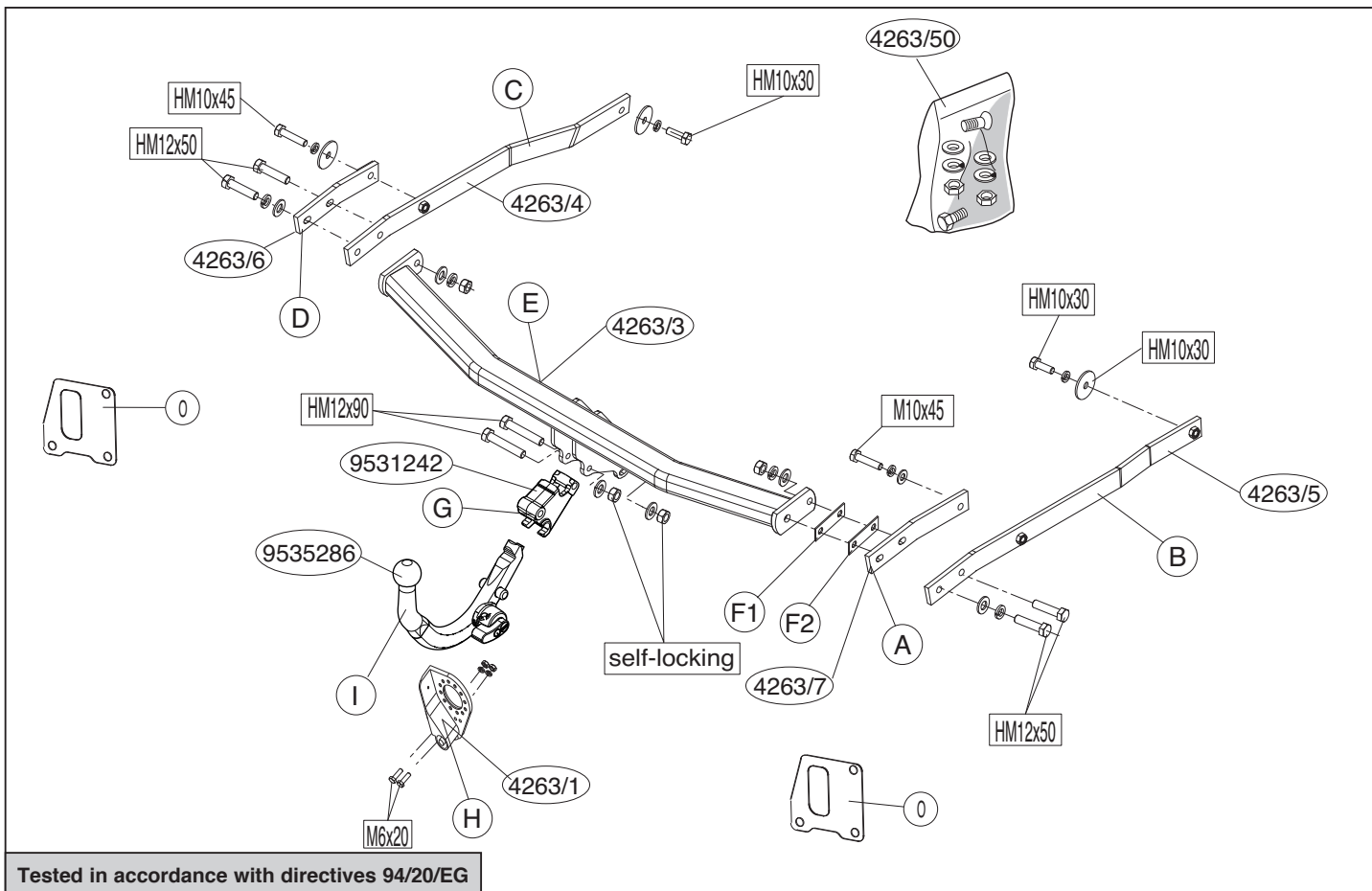



Tested in accordance with directives 94/20/EG

© 426370/02-10-2009/1



Dispositivo di traino tipo: Brink 4263
 Per autoveicoli: Renault Megane Sedan / CC; 2003->
 Tipo funzionale: oppure 194????? ???

Classe e tipo di attacco: A50-X
 Omologazione: e11 00-5416
 Valore D: 7,5 kN
 Carico Verticale max. S: 75 kg
 Larghezza rimorchiabile per Caravan e T.A.T.S.: 2,45m vedere CARTA di CIRCOLAZIONE VEICOLO (motrice) + 70 cm = ..arrotondare ai 5 cm superiore (vedi D.M.28/05/85)
 Massa rimorchiabile: vedi carta di circolazione dell' autoveicolo

Per verificare l'idoneità del dispositivo di traino omologato a norma CEE 94/20, all'installazione sulla vettura su cui si intende procedere al montaggio, compilare la seguente formula (se necessario declassare la massa rimorchiabile):

$$D = \frac{T \times C}{T + C} \times 0,00981 = \dots\dots\dots \text{kN}$$

dove: T= Massa Complessiva Max. della motrice (in kg)
 C= Massa Rimorchiabile Max. della motrice (in kg)

DA COMPILARE PER IL COLLAUDO

DICHIARAZIONE DI CORRETTO MONTAGGIO: la sottoscritta Ditta dichiara di aver montato in maniera corretta ed in conformi/ alle prescrizioni sia del costruttore del veicolo che del costruttore del dispositivo stesso il seguente dispositivo di attacco meccanico:

tipo:.....
 Il dispositivo di attacco sopra indicato è stato installato su autoveicolo
 modello:.....
 targa:.....
 Data:.....

TIMBRO e FIRMA

Si dichiara inoltre di aver informato l'utente del veicolo sull'USO e MANUTENZIONE del dispositivo stesso.

© 426370/02-10-2009/14

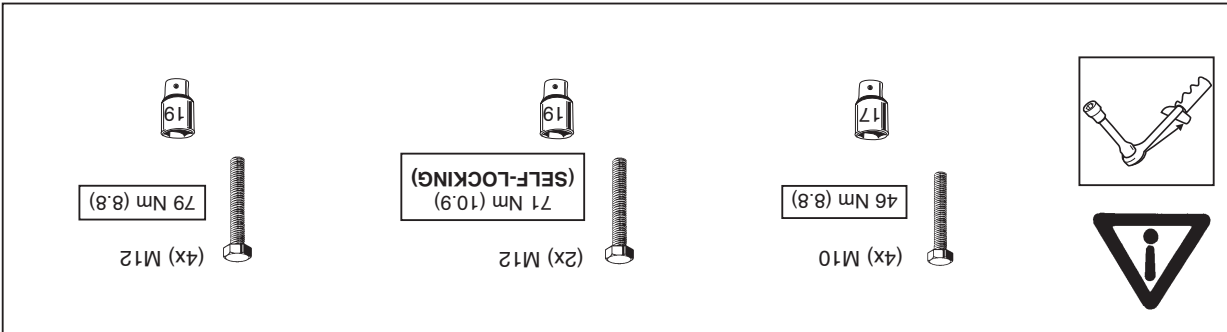
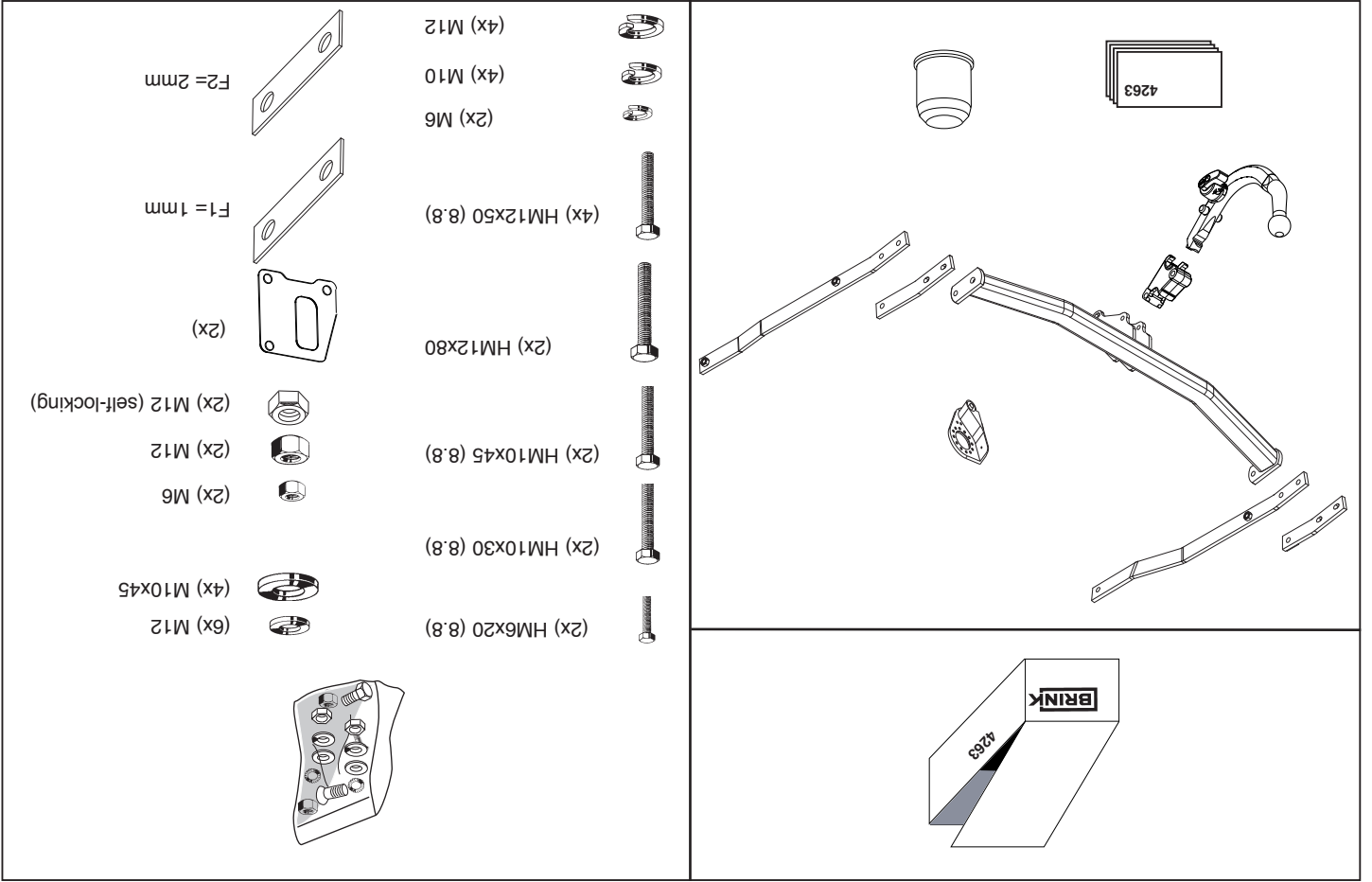

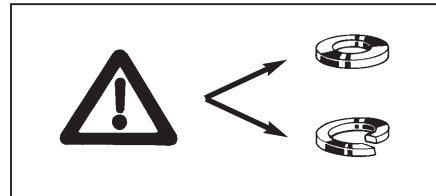
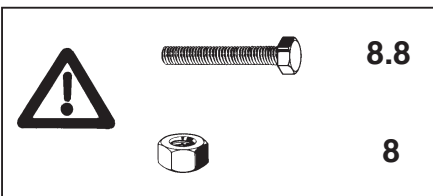
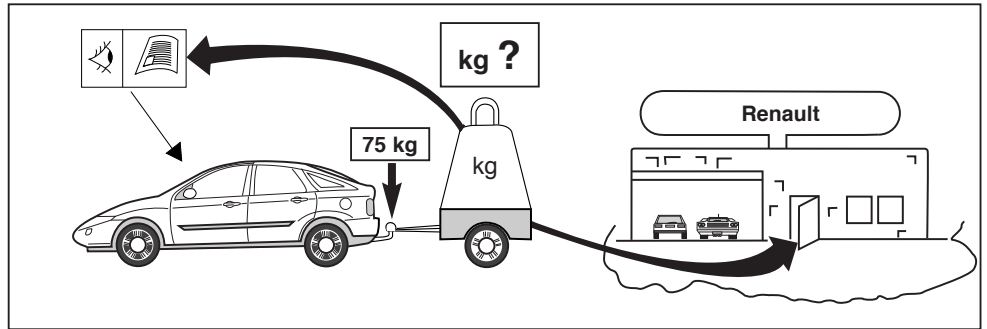
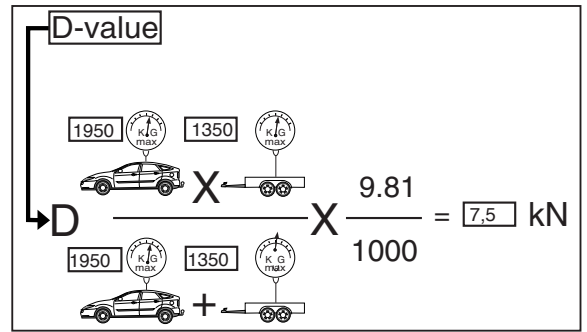
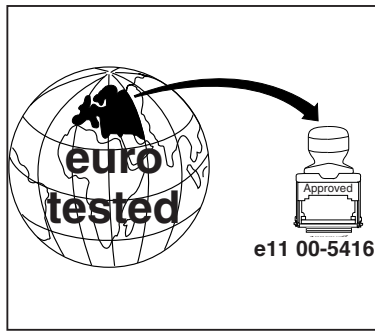
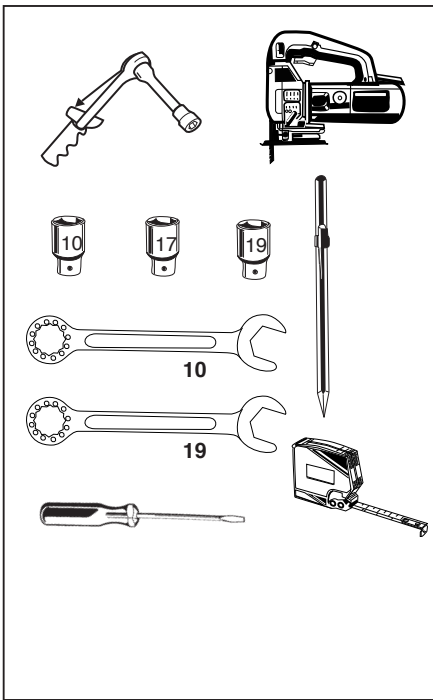

© 426370/02-10-2009/3

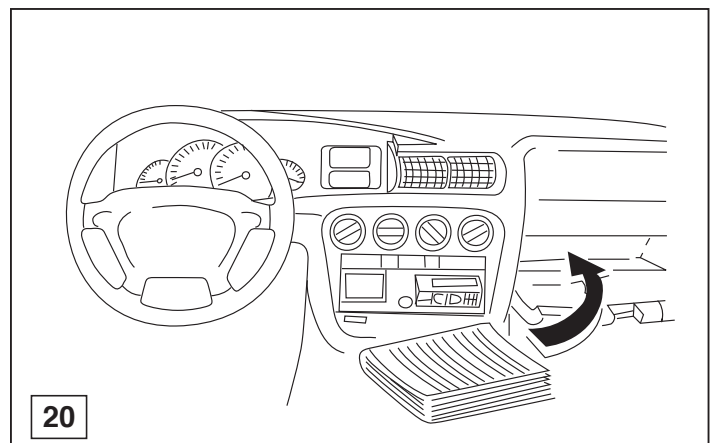
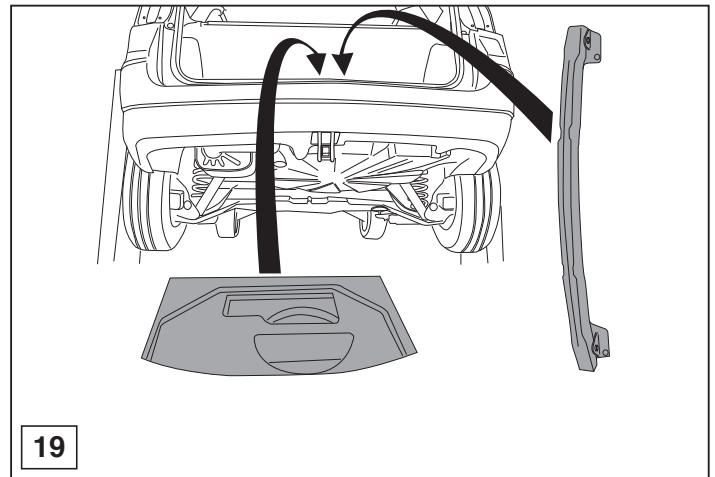
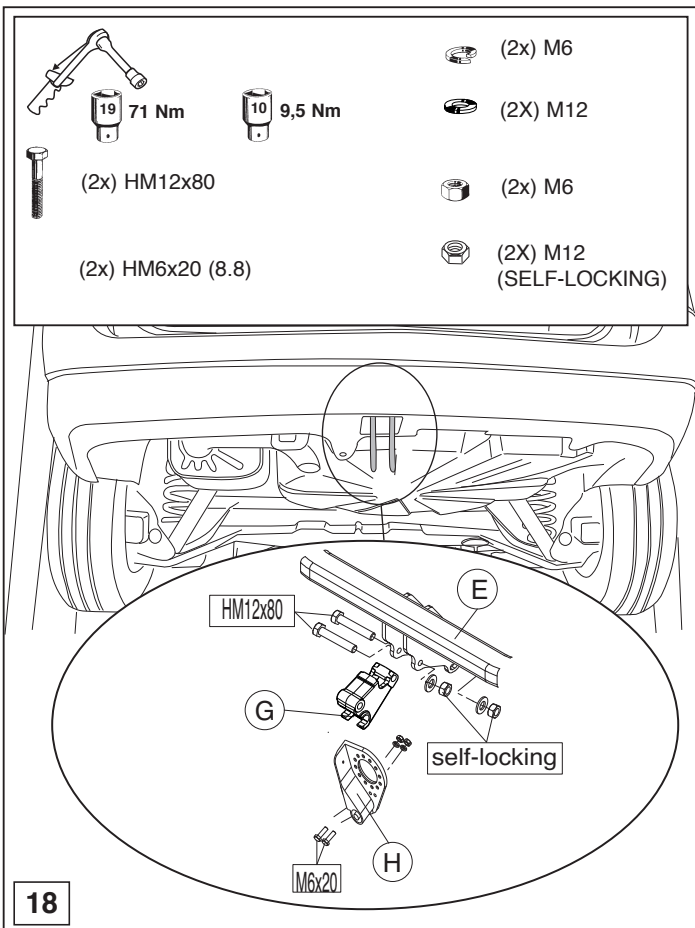

© 426370/02-10-2009/12





1000km

+

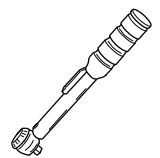

0km







M12
79 Nm 71 Nm (self-locking)



M10
46 Nm



M 6
9,5 Nm



Torque settings for nuts and bolts (8.8)

HINWEISE:

* Die für das Fahrzeug zugelassene Anhängelast ist den Fahrzeug Unterlagen zu entnehmen. Bei Änderungen des Fahrzeuggewichtes muß die höchstzulässige Anhängelast gegebenenfalls aus dem D-Wert nachgerechnet werden.

* Auskunft hierüber kann ihr Fachhändler oder der TÜV geben.

* Elektrische Anlage gemäß StVZO anbringen.

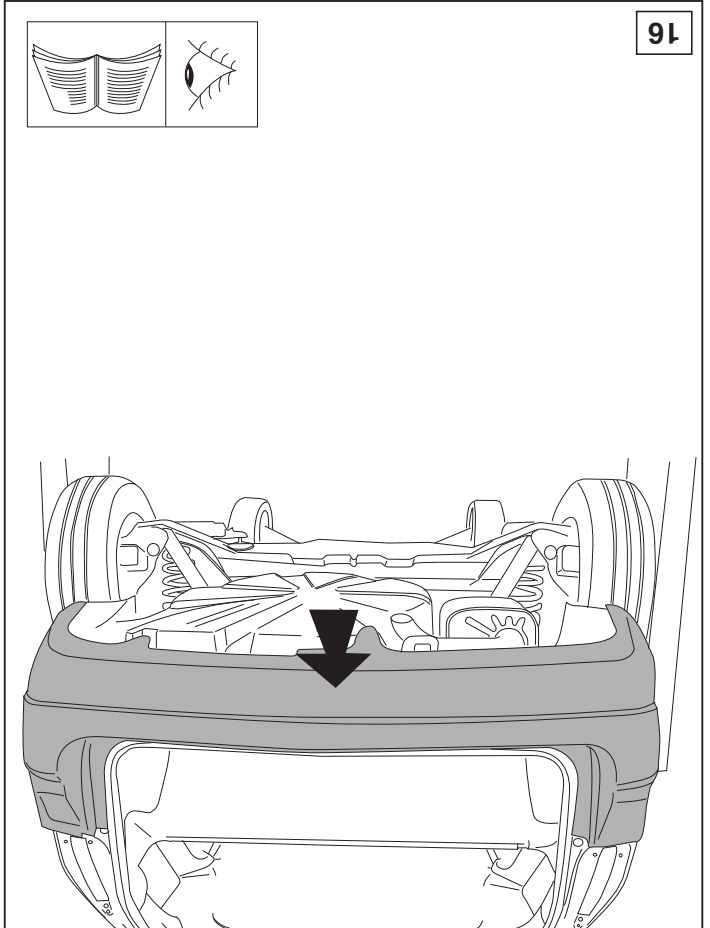
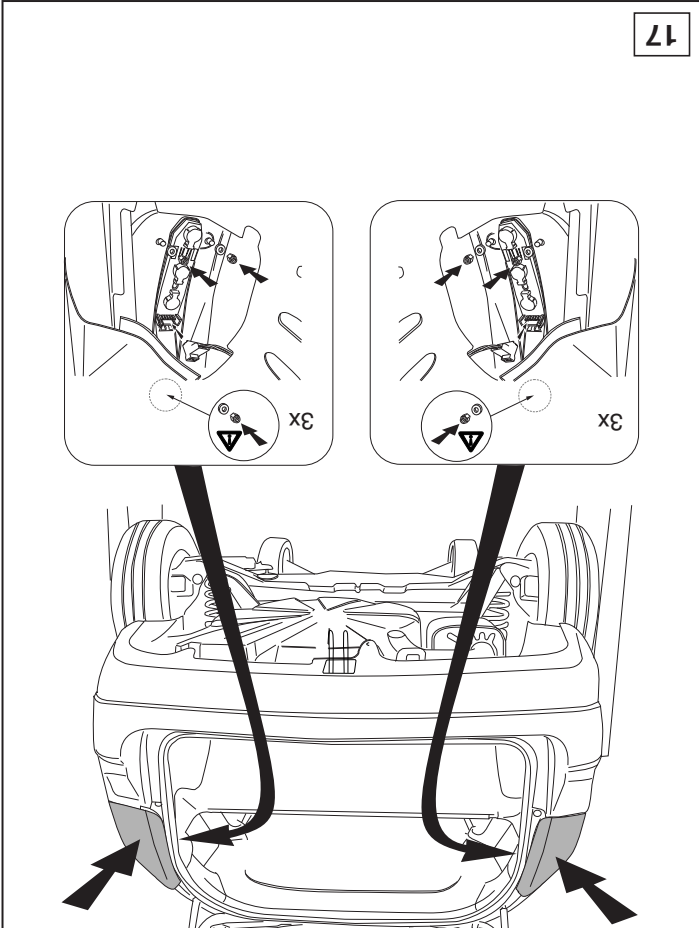

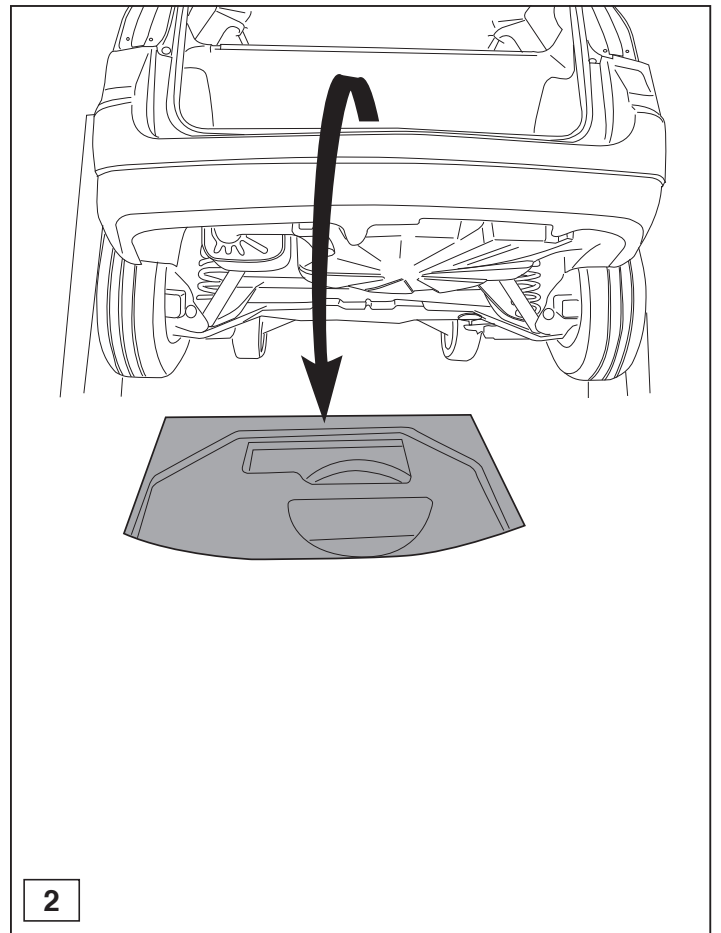
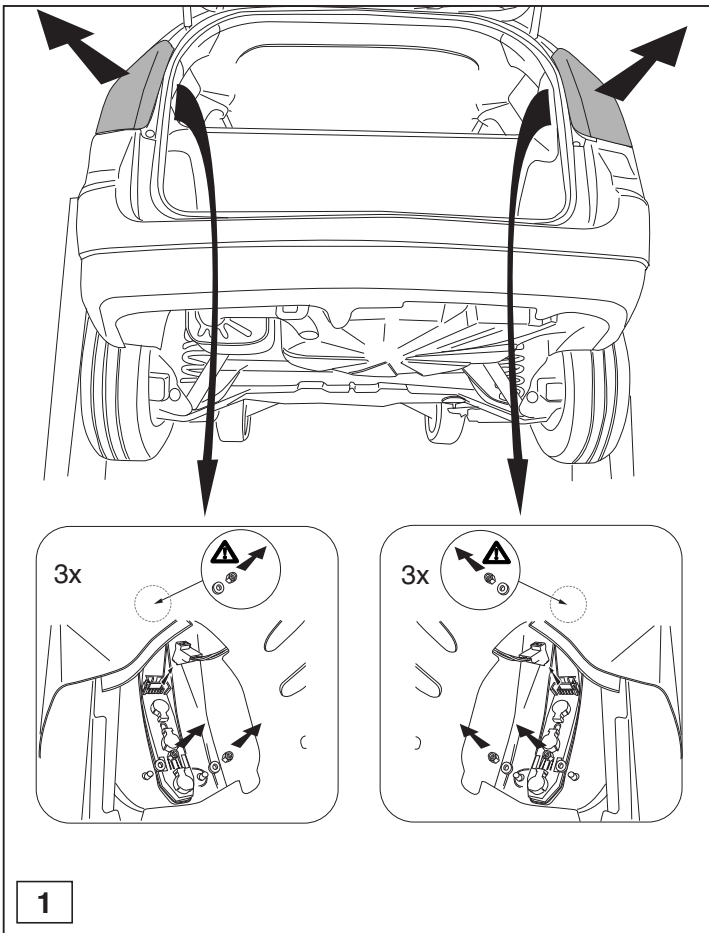

© 426370/02-10-2009/5

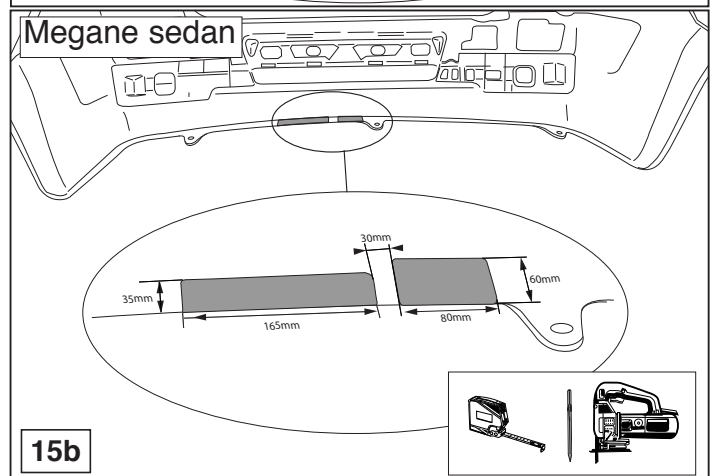
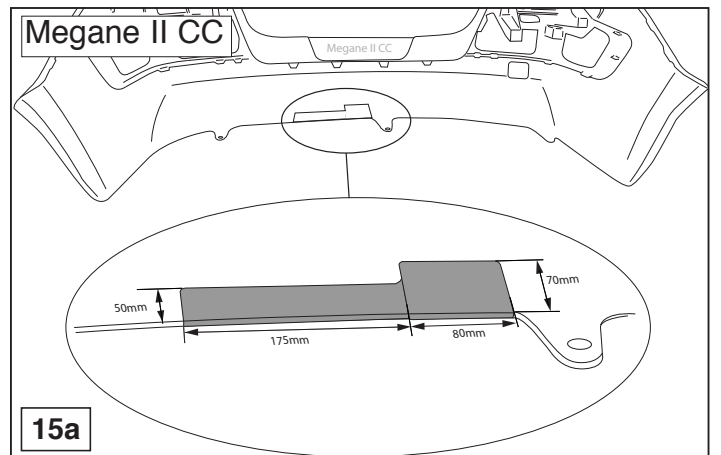
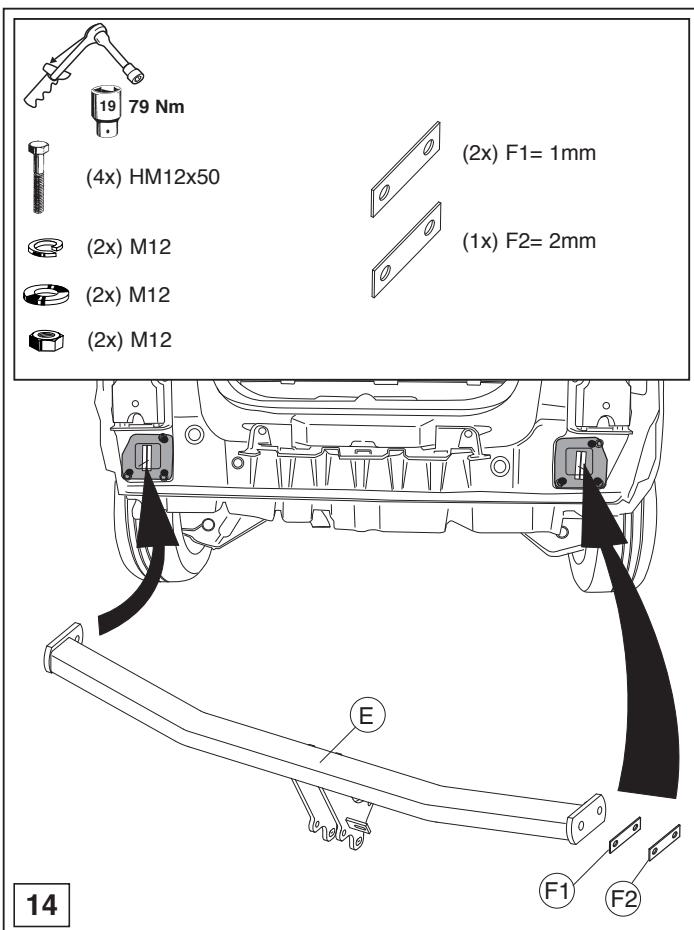

© 426370/02-10-2009/10

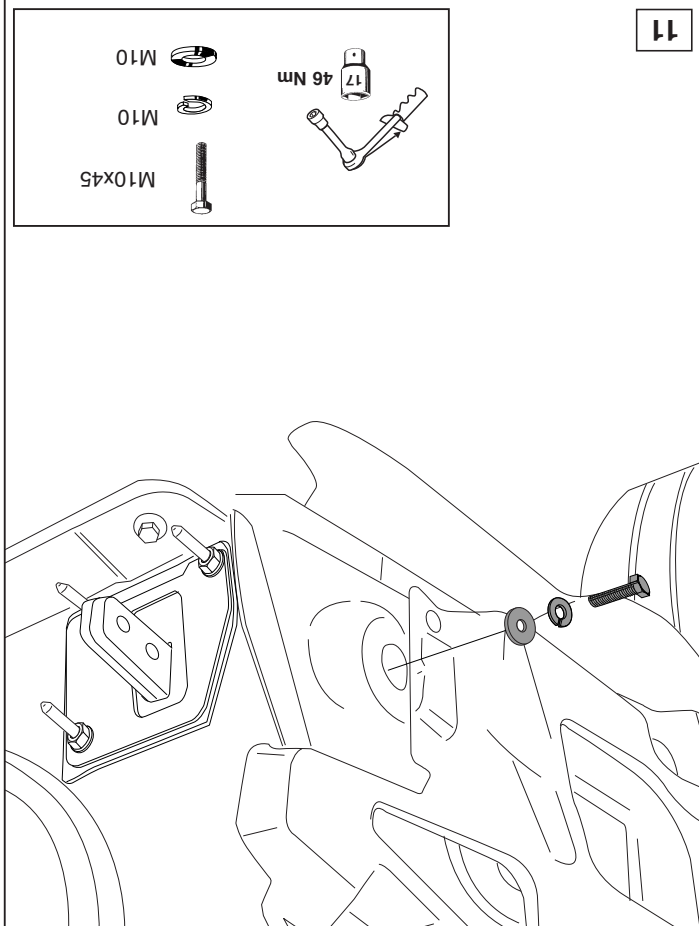
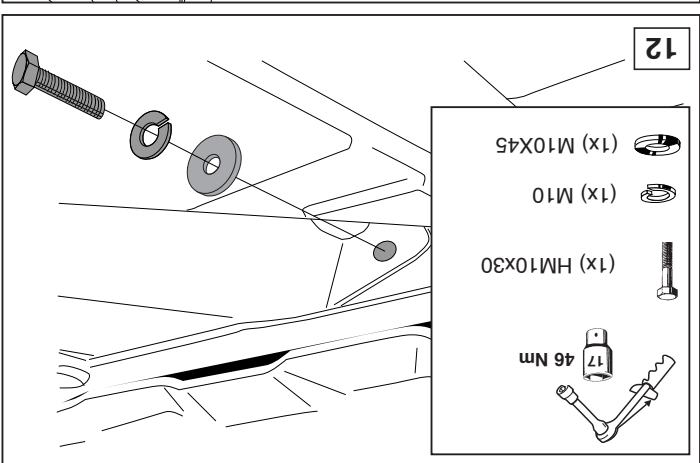
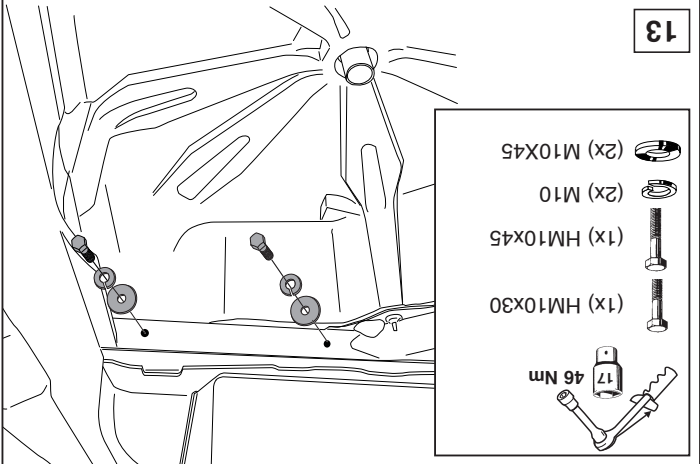
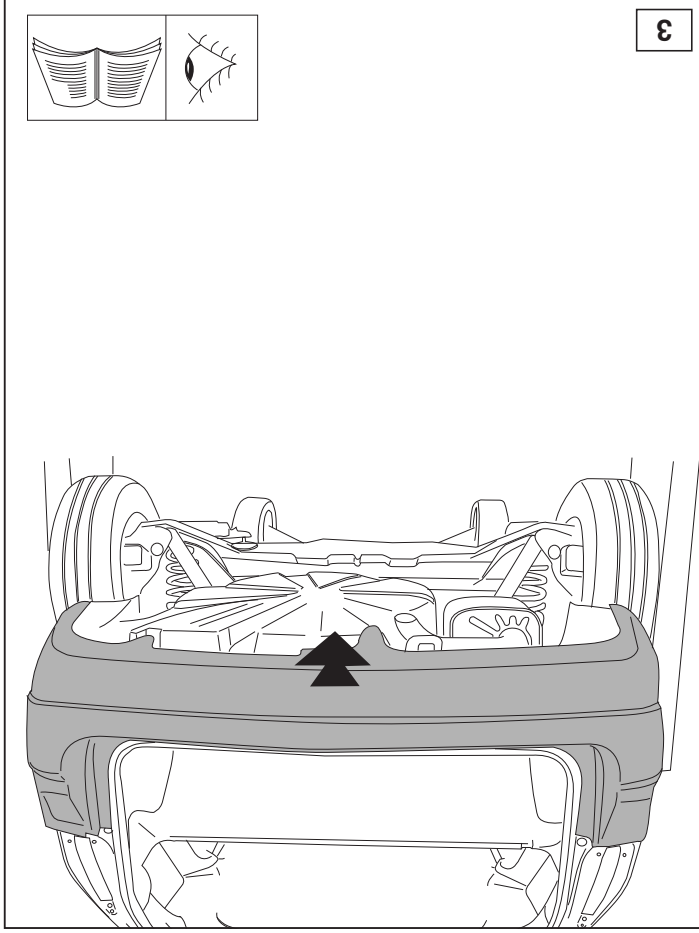
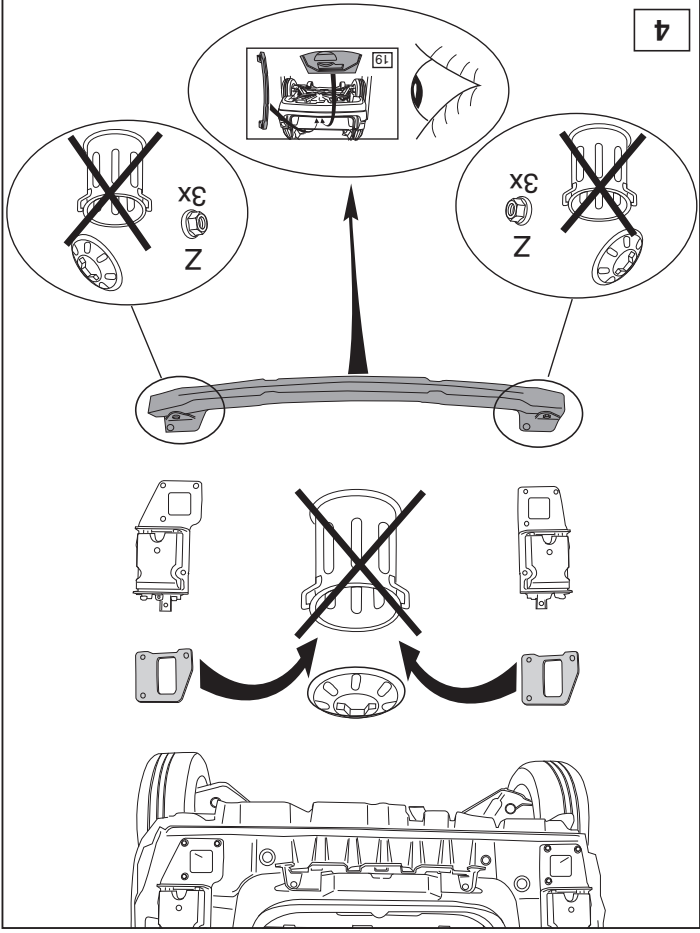

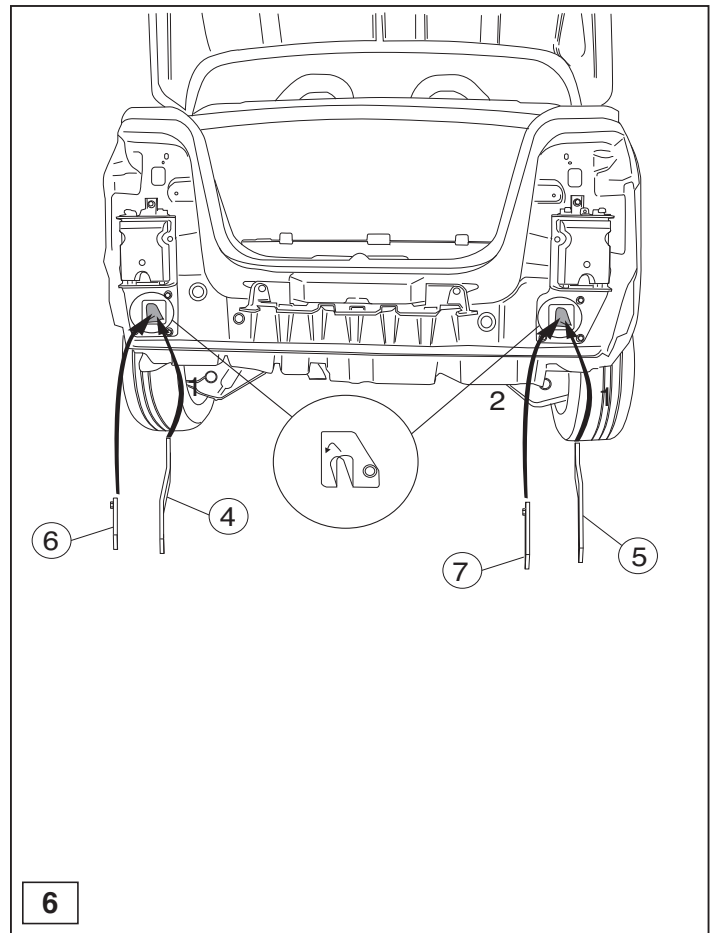
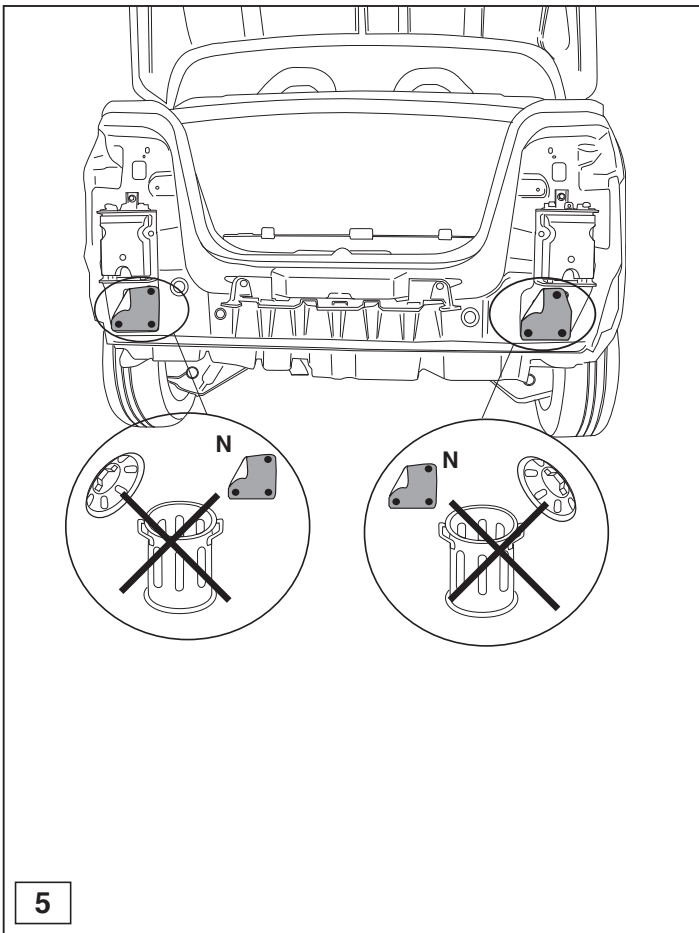

© 426370/02-10-2009/7

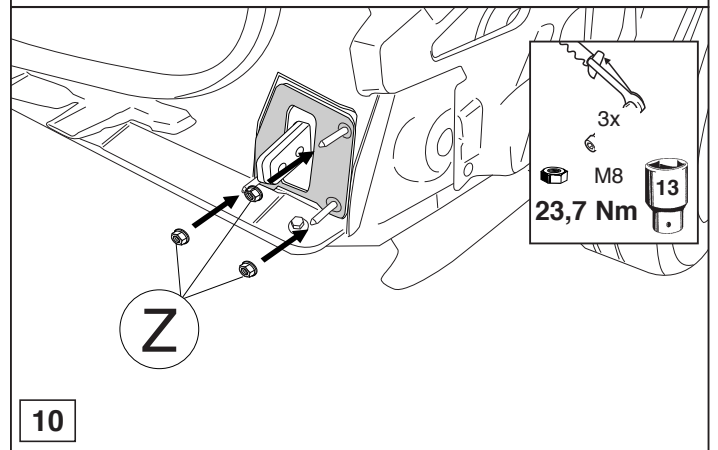
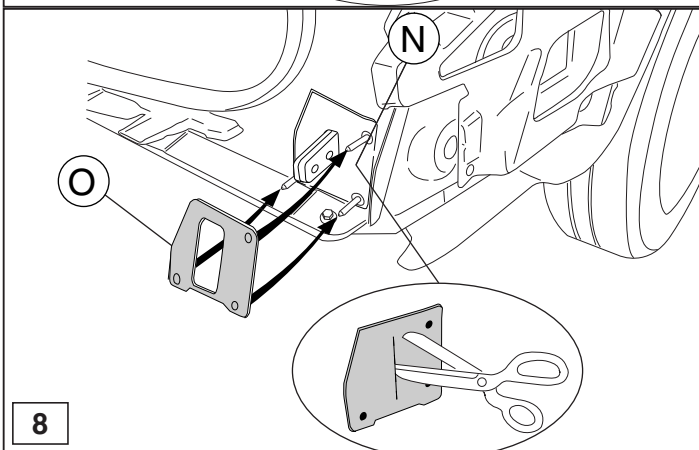
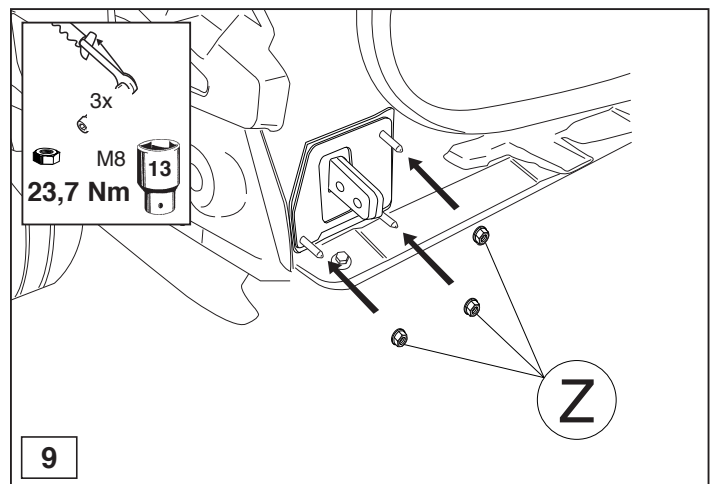
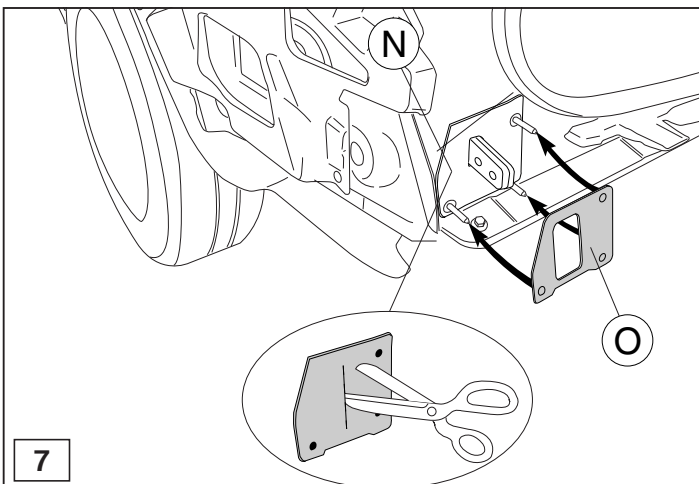

© 426370/02-10-2009/8