











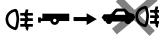

MONTAGE-HANDLEIDING ELEKTROSET VOOR TREKHAAK MET 13-POLIGE CONTACTDOOS VLGS. DIN/ISO NORM 11446

RENAULT MEGANE 5-D 1999-

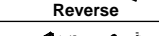
Bestel Nr.: RN-009-HB

1. Verwijder de negatieve klem van de accu.
Verwijder de kappen aan de linker- en rechterzijde onder de achterlichten.
2. Boor een gat van 40 mm aan de rechterzijde in de reservewiel bak.
Verwijder zorgvuldig alle metaalsplinters en behandel de randen met een anti-corrosiemiddel.
3. Leid de kabelboom door het gat de kofferruimte in en plaats de tule in het gat.
De draden zijn als volgt aangesloten:

DIN/ISO 11446		(D)	(F)	(GB)	(NL)
	1/L	gelb	jaune	yellow	geel
	2	blau	bleu	blue	blauw
	2a	grau	gris	grey	grijs
 1-8	3/31	weiß	blanc	white	wit
	4/R	grün	vert	green	groen
	5/58-R	braun	marron	brown	bruin
	6/54	rot	rouge	red	rood
	7/58-L	schwarz	noir	black	zwart
 Reverse	8	schwarz/rot	noir/rouge	black/red	zwart/rood
 30+	9	braun/weiß	marron/blanc	brown/white	bruin/wit
 15+	10	rot	rouge	red	rood
 10	11	weiß	blanc	white	wit
	12	rot/blau	rouge/bleu	red/blue	rood/blauw
 9	13	weiß	blanc	white	wit

Monteer de contactdoos op de contactdoosplaat.

4. Op de beide achterlicht units bevinden zich connectoren.
Neem deze connectoren uit elkaar.
Sluit de connectoren van de kabelboom met de grijze, groene, bruine en blauwe draad overeenkomstig aan de rechterzijde aan.
Sluit de connectoren van de kabelboom met de grijze, rood/zwarte, zwarte, rode en gele draad overeenkomstig aan de linkerzijde aan.
Bevestig de connectoren met de meegeleverde kabelbinders, zodat ze niet losraken (zie afbeelding).
Bevestig de ogen met de witte draden aan de rechterzijde aan de voertuig-massa.

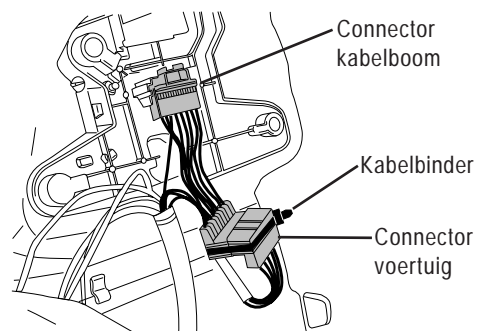











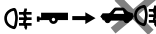

5. Leid de bruin/witte draad van de accu, langs de linkerzijde door het voertuig naar de 3-polige connector van de kabelboom.
Pas op voor scherpe delen!
Monteer de bruin/witte draad in de meegeleverde 3-polige connector op de positie die overeenkomt met de positie van de bruin/witte draad in de 3-polige connector van de kabelboom, en sluit beide connectoren op elkaar aan.
Monteer het oogje op de + pool. Bevestig de zekering met kapje.
6. Sluit de negatieve klem aan op de accu.
Controleer de elektrische functies met de aanhanger aangesloten.
Monteer alle gedemonteerde onderdelen.

EINBAUANLEITUNG ELEKTROSATZ ANHÄNGERVORRICHTUNG MIT 13-P STECKDOSE II.
DIN/ISO NORM 11446

RENAULT MEGANE 5-T 1999-

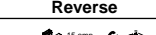
Bestell Nr.: RN-009-HB

- Das Minuskabel der Batterie entfernen.
Die Kappe an der linken und rechten Seite im Gepäckraum unter den Heckleuchten entfernen.
- An der rechten Seite in der Reserveradmulde ein 40 mm großes Loch bohren.
Sorgfältig alle Metallsplitter entfernen und die Kanten mit Rostschutz behandeln.
- Den Kabelsatz durch das Loch im Gepäckraum führen und die Tülle in dem Loch befestigen.
Die Kabel sind wie folgt angeschlossen:

DIN/ISO 11446		D	F	GB	NL
	1/L	gelb	jaune	yellow	geel
	2	blau	bleu	blue	blauw
	2a	grau	gris	grey	grijs
 1-8	3/31	weiß	blanc	white	wit
	4/R	grün	vert	green	groen
	5/58-R	braun	marron	brown	bruin
	6/54	rot	rouge	red	rood
	7/58-L	schwarz	noir	black	zwart
 Reverse	8	schwarz/rot	noir/rouge	black/red	zwart/rood
 30+	9	braun/weiß	marron/blanc	brown/white	bruin/wit
 15+	10	rot	rouge	red	rood
 10	11	weiß	blanc	white	wit
	12	rot/blau	rouge/bleu	red/blue	rood/blauw
 9	13	weiß	blanc	white	wit

Die Steckdose auf die Anhängerkupplung montieren.

- Auf den beiden Heckleuchtesätzen befinden sich Steckverbinder.
Diese Steckverbinder auseinandernehmen.
Die Steckverbinder des Kabelsatzes mit dem grauen, grünen, braunen und blauen Kabel übereinstimmend an der rechten Seite anschließen.
Die Steckverbinder des Kabelbaums mit dem grauen, rot/schwarzen, schwarzen, roten und gelben Kabel übereinstimmend an der linken Seite anschließen.
Die Steckverbinder mit den beige-lieferten Kabelbindern befestigen, damit diese festbleiben (siehe Abbildung).
Die Augen mit den weißen Kabeln an der rechten Seite an der Fahrzeugmasse befestigen.

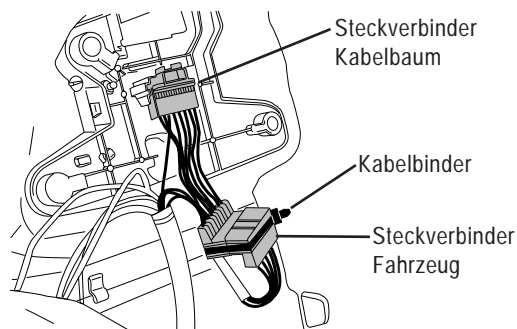













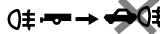

- Das braun/weiße Kabel von der Batterie, an der linken Seite entlang zum 3-poligen Steckverbinder des Kabelsatzes führen.
Achten auf scharfe Teile!
Das braun/weiße Kabel in den beiliegenden 3-poligen Steckverbinder montieren auf der Position, die mit der Position des braun/weißen Kabels in dem 3-poligen Steckverbinder des Kabelbaums übereinstimmt, und die beiden Steckverbinder anschließen.
Das Auge auf den +Pol montieren. Die Sicherung mit Kappe befestigen.
- Die Batterie wieder anschließen und sämtliche Fahrzeugfunktionen mit angeschlossenem Anhänger überprüfen.
Die abmontierten und entfernten Teile wieder montieren.

FITTING INSTRUCTIONS ELECTRIC WIRINGKIT TOWBAR WITH 13-P SOCKET UP TO DIN/ISO NORM 11446

RENAULT MEGANE 5-D 1999-

Partno.: RN-009-HB

1. Remove the battery earth cable.
Remove the covers at the left- and right-hand side under the rearlights.
2. Drill a 40 mm large hole at the right-hand side in the spare wheel housing.
Carefully remove all metal particles and treat the edges with anti-rust.
3. Lead the wiring harness through the hole in the boot and put the grommet in the hole.
The wires are connected as indicated:

DIN/ISO 11446		(D)	(F)	(GB)	(NL)
	1/L	gelb	jaune	yellow	geel
	2	blau	bleu	blue	blauw
	2a	grau	gris	grey	grijs
	3/31	weiß	blanc	white	wit
	4/R	grün	vert	green	groen
	5/58-R	braun	marron	brown	bruin
	6/54	rot	rouge	red	rood
	7/58-L	schwarz	noir	black	zwart
	8	schwarz/rot	noir/rouge	black/red	zwart/rood
	9	braun/weiß	marron/blanc	brown/white	bruin/wit
	10	rot	rouge	red	rood
	11	weiß	blanc	white	wit
	12	rot/blau	rouge/bleu	red/blue	rood/blauw
	13	weiß	blanc	white	wit

Mount the socket to the towbar.

4. At both rearlight units connectors are located.
Disconnect these connectors.
Connect the connectors of the wiring harness with the grey, green, brown and blue wire at the right-hand side.
Connect the connectors of the wiring harness with the grey, red/black, black, red and yellow wire at the left-hand side.
Tie the connectors with the supplied cable ties, to make sure they don't get loose (see picture).
Fit the ringtongues with the white wires at the right-hand side to chassis earth.

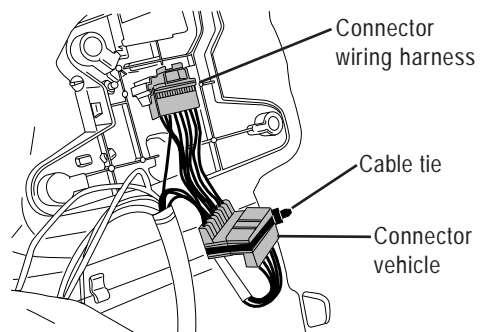













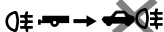

5. Lead the brown/white wire from the battery, at the left-hand side through the interior in the boot.
Careful. Sharp parts!
Fit the brown/white wire in the supplied 3-pole connector, at the position which corresponds to the position of the brown white wire in the 3-pole connector of the wiring harness, and fit both connectors together.
Fit the ringtongue to the + pole. Fit the fuse and cover.
6. Reconnect the battery and check all electric functions, with trailer/caravan connected.
Reinstall disassembled parts.

INSTRUCTION DE MONTAGE DU FAISCEAU ELECTRIQUE POUR CROCHET D'ATTELAGE
CONFORME A LA NORME DIN/ISO 11446 PRISE 13-P

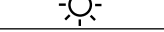
RENAULT MEGANE 5-P 1999-

Reference: RN-009-HB

- Débranchez la cosse négative de la batterie.
Enlevez les capots au côté gauche et droit sous les feux arrière.
- Percez un trou de 40 mm au côté droit dans la boîte du roue de secours.
Enlevez avec attention les échardes de métal et appliquez une peinture anti-corrosion sur les contours.
Placez le passe-fils dans le trou.
- Menez le faisceau électrique via le trou dans le coffre et placez le passe-fil dans le trou.
Les fils ont connecté comme indiqué ci-dessous:

DIN/ISO 11446	(D)	(F)	(GB)	(NL)	
	1/L	gelb	jaune	yellow	geel
	2	blau	bleu	blue	blauw
	2a	grau	gris	grey	grijs
 1-8	3/31	weiß	blanc	white	wit
	4/R	grün	vert	green	groen
	5/58-R	braun	marron	brown	bruin
	6/54	rot	rouge	red	rood
	7/58-L	schwarz	noir	black	zwart
 Reverse	8	schwarz/rot	noir/rouge	black/red	zwart/rood
 30+	9	braun/weiß	marron/blanc	brown/white	bruin/wit
 15+	10	rot	rouge	red	rood
 10	11	weiß	blanc	white	wit
	12	rot/blau	rouge/bleu	red/blue	rood/blauw
 9	13	weiß	blanc	white	wit

Montez la prise sur le crochet d'attelage.

- Sur les unités de feux arrière se trouvent des connecteurs.
Séparez les connecteurs du côté droit.
Connectez-y la terminaison ayant un fil de couleur grise, verte, marrone et bleue.
Séparez les connecteurs du côté gauche.
Connectez-y la terminaison ayant un fil de couleur grise, rouge/noire, jaune, noire et rouge.
Fixez les connecteurs avec les bandes d'attaches livrés (voir illustration).
Branchez les cosse avec les fils blancs au côté droit à la masse.

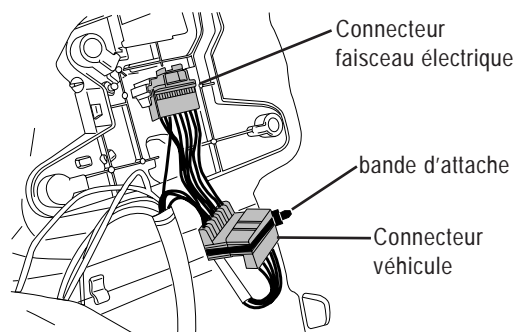

- Menez le fil marron/blanc de la batterie, à côté gauche via l'intérieur dans le coffre.
Attention aux pièces tranchantes!
Montez le fil marron/blanc dans le connecteur 3-pôles livré à la position qui correspond avec la position du fil marron/blanc dans le connecteur 3-pôles du faisceau électrique, et connectez les deux connecteurs.
Branchez la cosse circulaire sur le pôle positif de la batterie.
- Rebranchez la cosse négative de la batterie.
Contrôlez les fonctions avec la remorque accouplée.
Remontez les parts enlevés.